

**FY1999 Project for the Advise ment of Sustainable Development Support
Commissioned by Environment Agency, Government of Japan**

Text Book
for
Sampling for Environmental Monitoring
- Analysis Video Series for Environmental Technology Transfer -

March 2000

Overseas Environmental Cooperation Center, Japan

TABLE OF CONTENTS

	page
INTRODUCTION	1
PART I : ENGLISH NARRATION	4
• Prologue	5
• Sampling of Water	6
• Sampling of Ambient Air	9
• Sampling of Flue Gas	12
• Epilogue	14
PART II : DETAILED EXPLANATION NOT GIVEN IN THE VIDEO	15
Chapter 1. : Objectives and Significance of Environmental Sampling	16
Chapter 2. : Sampling of Water	19
Chapter 3. : Sampling of Ambient Air	37
Chapter 4. : Sampling of Flue Gas	46

Introduction

Following the 'Basic Operation in Chemical Analysis' of the previous year, this video – Sampling for Environmental Monitoring – has been produced by the Overseas Environmental Cooperation Center (OECC) as a visual guide for experts sent to environmental laboratories in developing countries to effectively conduct basic guidance in technology transfer as part of the 1999 Environment Agency project.

This video covers three main themes – Sampling of Water, Sampling of Ambient Air and Sampling of Flue Gas – for basic education on sampling, which is an important area in terms of environmental analysis technology.

In the production of this video, a committee comprising of the following members was established to discuss the scenarios and teaching material configurations, as well as authoring manuscripts as written supplements for technical details that could not be included in the video due to time restrictions.

Environmental Analysis Video Production Support Committee

Chairman:	Hajime Shirayama	Executive Assistant Researcher, Environmental Science Research Center, Toyama Prefecture Executive Assistant Researcher, Northwest Pacific Region Environmental Cooperation Center
Committee members:	Koichiro Hirano	Chief Engineer, Research Institute for Environmental Science, Yokohama City
	Kazuo Makino	Chief Professor, National Environmental Training Institute, Environment Agency
	Hiroshi Murata	Director, Environmental Coordination Division, Administration Center for Miura and Yokosuka Districts, Kanagawa Prefecture
	Yoshichika Watanabe	Former Chief Professor of the National Environmental Training Institute, Environment Agency

We would like to thank the Yokohama City Research Institute for Environmental Science and the Environmental Pollution and Health Testing Institute of the Kanagawa Pharmaceutical Association for their kind cooperation with the filming.

1. Video Contents

1) Prologue

Before launching into the main theme, the need for appropriate samples to be obtained for survey purposes is emphasized in order to secure accurate results through the conducted analysis to provide an objective understanding of the environment. In order to do so, field inspections must be conducted after clarifying the survey objectives, appropriate sampling plans must be drawn up, and accurate methodology must be used to carry out such sampling after sufficient preparation.

2) Sampling of Water

First there is an explanation of the different water samples, and the various types of vessels used for each sampling method are introduced along with notes on their usage. Secondly, the full process of taking water samples from a river is introduced. This covers field observation, taking records in field notes, measurement of basic field data (such as flow velocity, temperature, pH, transparency, etc.), the transfer of collected water into vessels, and pretreatment work for sample storage. Thirdly, the collection of bottom-layer water samples from great depths and transparency measurements are explained, while collection of factory effluent completes this topic.

3) Sampling of Ambient Air

It begins with an explanation that gaseous and particulate matters exist as forms of air pollutants. A number of methods are employed to collect gaseous pollutants, such as using absorbents, adsorbents, and vessels, and the specific collection procedures for each method are introduced. It explains that an important item during the collection process is the accurate measurement of the air flow rate. It also describes the necessity of calibration in order to do so, as well as introducing types of measuring devices. Secondly, concerning collection of particulate matter, it explains how to use the equipment and filter papers, etc., with low volume and high volume air samplers. Finally, diffusion samplers – which are convenient for simplified measurements – are introduced.

4) Sampling of Flue Gas

As above, this pollution falls into two categories, namely gaseous and particulate pollutants. Flue gases from waste incinerators are sampled to check oxides of sulfur and nitrogen (SO_x / NO_x). Additionally, actual operations to measure moisture content and oxygen density within the flue gas are introduced. Isokinetic sampling is the most important point to consider when sampling for particulate pollutants in flue ducts. Explanations on how to set the filter paper at the tip of the probe are introduced as well as making actual measurements using a pitot tube.

2. Contents of the Attached Text

This text is made up of Parts One and Two as supplements to the video.

Part One contains the final version of the shooting scenario scripts that were created for video editing, and subsequently modified to match the images and narration upon completion. An English narration that has been recorded for the video is also included to facilitate its use when providing technical instruction to counterparts and for translation into local languages.

Part Two covers supplementary issues and subjects that could not be included in the video due to time restrictions. The authors of each chapter are introduced as follows.

- Chapter 1. Objectives and Significance of Environmental Sampling Hiroshi Murata
(Kanagawa Prefecture)
- Chapter 2. Sampling of Water (2.1, 2.5, 2.6) Hajime Shirayama (Toyama Prefecture)
Sampling of Water (2.2, 2.3, 2.4) Yoshichika Watanabe (Retired from Environment Agency)
- Chapter 3. Sampling of Ambient Air Koichiro Hirano (Yokohama City)
- Chapter 4. Sampling of Flue gas Mitsuru Fujimura (Green Blue)

March 2000

Overseas Environmental Cooperation Center, Japan

PART I

ENGLISH NARRATION

Sampling for Environmental Monitoring

- **Prologue**
- **Sampling of Water**
- **Sampling of Ambient Air**
- **Sampling of Flue Gas**
- **Epilogue**

SAMPLING FOR ENVIRONMENTAL MONITORING

Analysis Video Series for Environmental Technology Transfer, No. 2

PROLOGUE

Explanation 1

Environmental survey and analysis is among the methods used to obtain objective information on the environment around us. The collecting of appropriate samples which meet survey objectives in an environmental analysis is the key to the obtaining of accurate environmental data.

Explanation 2

Samples which are collected for use in environmental analysis include water, solid material and air samples.

Water samples are collected from rivers, lakes, the ocean, underground water, industrial waste water which is discharged from factories and household waste water.

In addition, various solid samples are collected such as soil, bottom sediment, sludge and solid waste.

Gaseous samples include airborne dust, noxious gases in the atmosphere, soot and dust released from factories, and exhaust from motor vehicles.

This video will focus primarily on the taking of air and water samples, and sampling at the source will also be touched upon.

Explanation 3

It is important to understand the sampling objectives when setting up a sampling plan. For example, is a survey being conducted to comply with regulatory requirements or is it designed to monitor the present pollution conditions.

The survey site must be carefully considered, making sure it is appropriate to meet the survey objectives.

A survey season and period then needs to be set down so that representative samples can be obtained.

The parameters of analysis and the corresponding measurement methods must also be carefully considered to make sure that all requirements are covered without any redundancy.

The success of a survey will depend largely on the accuracy of the sampling design.

Explanation 4

The collection methods and tools to be used will depend on the characteristics of the targeted sample, and it is important to conduct the sampling in accordance with established procedures.

On-site observations can also represent important information for use in later evaluations, and you should make sure to take detailed field notes.

SAMPLING OF WATER

Explanation 5

Let's first look at the sampling methods used in water quality surveys.

Explanation 6

The water quality in rivers and streams is affected by daily human activity, industry and the natural environment itself.

The basic water quality indicators include pH, BOD, COD, dissolved oxygen and turbidity. Cyanides and pesticides can also be considered toxic substances. Important indicators related to eutrophication are nitrogen and phosphorous compounds. Another areas of concern are heavy metals originating from factories and mines.

Explanation 7

Thorough preparation is essential to smooth sampling work on-site. You should bring whatever backups you can. There have been cases where a job could not be completed simply for the lack of a single tool, spare part or reagent. Prepare properly to avoid such incidents.

Explanation 8

The type of sample containers should be selected corresponding to the type of analyses planned.

For example, as can be seen here, plastic and glass bottles of all sizes corresponding to the materials to be analyzed are brought to the site. Samples are placed in the containers and taken back to the laboratory.

Polyethylene bottles are widely used in the collection of COD, BOD and metal samples because they are light and shock resistant. However, the concentration of gases and some liquids can change slightly if stored for a long time in polyethylene containers because they can pass through polyethylene. Also minute amounts of metals and oils can adhere more readily to polyethylene in comparison to glass.

Glass has the drawback that it breaks easily, but it is suitable for use with minute amounts of organic substances and the analysis of trace heavy metals. Amber colored

glass bottles are used for substances which breakdown under exposure to light such as pesticides.

Commercially pre-sterilized bottles are used to collect samples for micro-biological testing such as for coliforms.

When glass containers in stock are used, they are first sterilized in an autoclave.

Explanation 9

Next let's look at the general procedures for collecting river water.

Water samples ideally should be taken on both banks of the river and in the center of the water flow. However when only one sample from a single location is taken, the water should be collected close to the center of the flow from an accessible spot such as on a bridge.

Explanation 10

You should get into the habit of concisely recording the on-site conditions that you observe. Information on the weather and sunlight conditions, condition of the embankments and river bottom together with information on flora and fauna will later serve as a valuable resource for evaluation.

You should measure the flow velocity, as necessary, and the width and depth of the river.

Explanation 11

Equipment which is easy to use on-site such as a bucket with a rope attached or scoop should be used to collect surface water. Make sure to collect water that does not contain mud when the river bed is shallow.

Record the color, turbidity, and the presence of suspended solids and sediment in the collected sample.

Explanation 12

Water temperature is normally measured with a glass thermometer immediately after the sample is collected or by directly measuring the sampled body of water on-site. A large sample should be collected when using a bucket to avoid the effects of air temperature. The thermometer should be inserted up to the upper edge and allowed to stand five minutes before taking a reading.

Explanation 13

A basic water quality parameter is the hydrogen ion concentration index or pH. pH is often measured these days with a portable pH meter.

These on-site measurements will constitute the basic parameters used to evaluate whether an appropriate water sample has been taken. So let's make sure everything is done correctly.

Explanation 14

Rinse out the inside of the bottles on-site several times using a small amount of the collected water. The amount of water to be collected will be determined based on the survey objectives and the amount required for analysis. More than enough water should be collected just in case an analysis has to be redone.

The sample containers should be labeled with a number or affixed with a label that cannot be removed so that the collection site and sample number can be identified on site.

Explanation 15

Water samples that are to be used to measure dissolved oxygen should be collected in such a way that contact with air is minimized.

The sample is poured in so as not to form air bubbles and the inside of the bottle is washed out.

Next the sample is gently poured into the container so that bubbles on the sides of the bottle are removed. Also tap the side of the bottle to fully ensure that all bubbles are disappeared.

A magnesium sulfate solution and potassium iodide-sodium azide solution are added to fix dissolved oxygen in the sample.

The solution is overflowed to remove air, a stopper is inserted, and the bottle repeatedly turned upside down to mix the solution.

Explanation 16

Since metals can adhere to the side of the sample containers, nitric acid or hydrochloric acid is added to set the pH at 1 and the sample is stored.

In addition, a small amount of sodium hydroxide is added to samples to be used in the analysis of cyanides.

Samples to be used in the analysis of BOD, COD, nitrogen oxides and phosphorus compounds should be transported in a cooler or polystyrene box containing ice or a coolant. These samples should be analyzed immediately after delivery to the laboratory.

Explanation 17

Turbidity can be measured using a variety of methods. The simplest way is to measure the transparency.

First put the water sample into a transparency meter. Then slowly release the water sample while observing it from directly above.

Stop draining the water when the two lines which form a cross on the bottom can be clearly distinguished. The depth at this moment should be recorded in centimeters. This method is appropriate for use when the turbidity is relatively high.

Explanation 18

An Ekman Barge dredger is used in the sampling of the river bottom and three or more samples are collected.

The collected samples taken back to the laboratory should weigh about 1 kilogram.

Explanation 19

Next let's take a look at collecting bottom layer water in lakes and seas.

A Vandorn water sampler which is lowered to the desired depth is used in the collection of bottom layer water. Next a messenger is dropped and the lid of the water sampler is closed.

After retrieving the water sampler, the cock on the rubber tube is opened and the sample transferred to another container.

Explanation 20

The transparency of lake and sea water is determined by immersing a white secchi plate with a diameter of about 25 to 30 centimeters in the water, and recording the depth in meters at which it cannot be seen.

Explanation 21

The sampling of water discharged from plants and businesses is generally conducted in drainage channels, pits and discharge ducts just prior to the release of the water into the river or sewer system.

The tools, containers and procedures used in the collection of these samples is almost the same as those used in environmental water sampling. The collection time should be set, taking into consideration the plant operation, and a typical discharge sample should be collected.

SAMPLING OF AMBIENT AIR

Explanation 22

A wide variety of pollutants are present in the air that we breathe. These pollutants include both those generated by the natural world and those generated by human activity. Some are present in the form of gases and others are suspended in air in the form of particulate matter.

Explanation 23

Sampling of noxious gases found in small amounts in the atmosphere is usually conducted either by collection using an absorbing solution or collection using a solid adsorbent. Let's look at the guidelines for basic on-site handling.

Explanation 24

Different absorbents are placed in a gas absorption bottle such as an impinger corresponding to the targeted compounds.

The suction tube is connected to a trap, pump and gas meter, and a fixed amount of air is drawn into the system.

Explanation 25

A method employing an adsorbent-packed cartridge tube is often used in the capture of gases such as hydrocarbons and formaldehyde.

A moisture absorption tube is attached in front of the cartridge tube during sampling and air is sucked in using a pump.

Explanation 26

Gases that are difficult to capture with an adsorbent are collected with a vacuum canister.

Collection via a bag using a pump is also an option.

Explanation 27

Different types of pumps such as a diaphragm pump, linear pump and rotary pump are used in the collection of air samples.

Explanation 28

The volume of air, which has been sampled, must be measured when determining the concentration of matter in air. Air volume data is an important factor which determines the final concentration value.

An integrating gas meter and a float flow meter are used in the measurement of air volume.

There are two types of gas meters available, wet and dry.

The wet gas meter is highly precise, and is often used as a reference device. However it is fragile and takes some effort to use because it contains water.

The dry gas meter is easy to operate and widely used in actual sampling. However it must be regularly calibrated using a reference device.

Explanation 29

If a reading of the gas meter is taken when sampling is started, then the volume can be calculated by determining the difference with the final reading.

To calculate the suction flow rate, you should measure the number of seconds required for the needle to rotate once several times using a stopwatch.

Explanation 30

In the regulation of the suction flow rate, a direct reading can be obtained for the flow rate if a float rotor meter is installed.

The rotor meter gives different values based on the pressure conditions or the pulsation depending the suction pump which is used. A scale calibration must be conducted in advance under the same conditions and using the same devices as the actual sampling.

Explanation 31

Particulate matter is sampled by filtration using a filter paper. The simplest method is inserting circular filter paper to the filter paper holder and drawing in air.

This is where the filter paper is inserted in the low volume air sampler filter holder.

The filter holder is normally set up at 1.2 meters above ground.

Explanation 32

Appropriate tubes that do not bend or break are used to connect the sampler, flow meter and pump. In addition, the tube should be firmly connected so that air does not leak at the connection points or come off during sampling.

Explanation 33

Take care to make sure that rain water does not get into the switch or connections of the electrical cords.

Explanation 34

A high volume sampler can collect a large volume of soot and dust in a short period of time, thus it is frequently used in surveys of the ambient air.

High volume air samplers come in two types. One sampler is equipped with a separator that allows only particles smaller than 10 μm or 2.5 μm to pass through. The other sampler, an open face type, allows all particles to pass through.

Explanation 35

The sampler is placed in an appropriate location where the wind passes through, and it is fixed in place with heavy weights or rope.

If the electrical cord is extended with a cord reel, make sure to fully unroll the cord because excess heat can be generated by the induced current if it is not.

Explanation 36

A glass fiber filter or quartz fiber filter are used in the collection of airborne dust. Once a filter is inserted in the holder, the blower motor is turned on, and the volume controller adjusted to a set suction flow rate.

The pre-sampling filter and post-sampling filter are weighed on a balance after humidification for more than a day and a constant weight achieved.

Explanation 37

A diffusion sampler is an extremely effective device when there is no on-site power source or sampling is being performed simultaneously at multiple sites.

There are several different types of diffusion samplers, but in all cases the gas molecules pass through pores and fine crevices until they reach the absorbent and are collected by the chemical reaction.

These samplers are simple and compact. They do not require a pump and can be used to quantitatively collect the target material by placing it in a shed to avoid rain and direct sunlight and exposing it to the atmosphere for a fixed period.

SAMPLING OF FLUE GAS

Explanation 38

A measuring hole and work place are required in the sampling of flue gas from facilities such as factories which emit soot and smoke.

This is an example of a stack in an incinerator. The measuring hole should be placed at a straight part of the stack where it is thought that the flue gas flow is steady and uniform.

Explanation 39

The measuring hole should be set up in a location where work can safely be done and a suction tube can be inserted at a right angle into the flow of the flue gas.

Normally the hole is covered with a lid.

The flange bolt on the measuring hole is removed, and the lid taken off when the flue gas is measured.

Explanation 40

Sulfur oxides in the flue gas are collected by drawing the flue gas into an absorption bottle containing hydrogen peroxide.

The sample gas is drawn for 20 to 30 minutes at a flow rate of approximately 1 liter per minute.

A ribbon heater is wrapped around the sampling tube to warm it and prevent the condensation of moisture on the inside of the tube.

Explanation 41

The sampling of nitrogen oxides in flue gas is done by collecting the gas using a vacuum flask or syringe. The vacuum flask contains acidic hydrogen peroxide with sulfuric acid for the oxidation of the nitrogen oxides.

As always, the concentration of nitrogen oxides in flue gas is converted based on the standard oxygen concentration in order to compensate for the effects of dilution through the mixing of air. The oxygen concentration in flue gas is measured for this reason.

Explanation 42

The measurement of dust and soot is performed by filtration using a filter and measuring the weight.

Circular or cylindrical filter paper is used corresponding to the amount of soot and dust to be collected.

Explanation 43

Care must be taken that the suction velocity of the collection nozzle and velocity of the flue gas flow correspond when drawing in soot and dust. This is called isokinetic sampling.

For this purpose, the flue gas flow velocity is measured with a Pitot tube and manometer.

This type of special Pitot tube is normally used in the measurement of duct flue gas.

The dynamic pressure created by the flow of the flue gas is measured using an inclined manometer and the flow velocity is calculated.

Explanation 44

The moisture content in the flue gas must be measured in the measurement of the soot and dust concentration. The flue gas is drawn in through a moisture absorption tube containing calcium chloride and the moisture is absorbed.

The weight of the moisture absorption tube is measured on a druggists' scale, and the moisture content is calculated based on the change in weight.

When collecting a sample using circular filter paper, a pre-weighed filter paper is set in the holder.

A nozzle that meets the isokinetic sampling conditions is attached and wrapped with tape to make sure it does not come loose.

A collection tube with a filter paper holder at the tip is inserted through the measuring hole to a set length within the duct and fixed into place.

A suction pump is connected and the sampling begun.

The filter holder is allowed to cool after the sampling is completed and the circular filter paper removed.

EPILOGUE

Explanation 45

Sampling is the starting point for an objective approach to environmental problems.

If sampling is not done properly, then the data gathered will be meaningless no matter how sophisticated the equipment used, how expert the laboratory technician or how accurate the analysis. It does not stop there, erroneous conclusions could be drawn and misguided decisions could be made.

Explanation 46

Above all, regular observation of the survey field and careful sampling are important. An adequate advance survey, comprehensive sampling design and in-depth preparation are critical to successful environmental analysis. Researchers themselves must be sufficiently familiar with the sampling site, and fully understand the entire process from sampling, analysis through to conclusion.

PART II

DETAILED EXPLANATION NOT GIVEN IN THE VIDEO

Chapter 1: Objectives and Significance of Environmental Sampling

Hiroshi Murata: Director, Environmental Coordination Division,
Administration Center for Miura and Yokosuka District,
Kanagawa Prefecture

Chapter 2: Sampling of Water

Section 1, 5, 6

Hajime Shirayama: Executive Assistant Researcher,
Environmental Science Research Center, Toyama Prefecture
Northwest Pacific Region Environmental Cooperation Center

Section 2, 3, 4

Yoshichika Watanabe: Former Chief Professor,
National Environmental Training Institute, Environment Agency

Chapter 3: Sampling of Ambient Air

Koichiro Hirano: Chief Engineer,
Research Institute for Environmental Science, Yokohama City

Chapter 4: Sampling of Flue Gas

Mitsuru Fujimura: Senior Engineer, Green Blue Corporation

1. Objectives and Significance of Environmental Sampling

1.1 Clearly Understanding the Objectives and Significance

The objectives and significance must be clearly understood when environmental sampling is carried out. Field records and analysis data obtained using analytical instruments are required if we are to correctly evaluate the environmental situation, and such data must be representative of the environment. In order to obtain accurate environmental data, it is imperative that the analysis samples be representative. However, they are not particularly easy to collect, so can only be accumulated through appropriate planning and implementation of sampling.

In terms of types of aquatic sampling, we include river water, seawater, and factory effluent sampling. With regard to air sampling, we look at flue gases from factories and vehicles, as well as ambient air sampling. Sometimes riverbeds are also sampled.

As stated before, the most important issue when drawing up a plan for sampling is to clearly understand its significance and objectives. In other words, we must correctly determine how, why, and what to conduct the survey on. Furthermore, sampling work should be undertaken according to specified procedures. In this case, it is important to use samplers and sample containers that are suited to the task.

Regular surveys are required to provide successive sampling analysis data in order to identify environmental changes, so such sampling must be consistent in its methodology and location. A very high degree of accuracy is required when undertaking sampling to determine whether the law is being met. When sampling under accident conditions, data should be obtained to accurately establish the cause(s) and evaluate the state of the site in order to discuss appropriate countermeasures.

The above points are simplified in the chart on the following page. We trust it is useful for field observations, planning surveys, and carrying out sampling.

1.2 Notes on Fixed Point Environmental Observations

Surveys should be planned, prepared, and conducted with due consideration for the items shown in the following chart when conducting regular surveys at a specified point.

	Water Measurements	Air Measurements
Planning	<p>River and sea water survey</p> <ul style="list-style-type: none"> — Select the point (What is it representative of?) — Confirm survey date and site (map) Sampling method / survey items — Storage and pretreatment of samples — Number of measurement times / analysis parameters <p>Factory effluent survey</p> <ul style="list-style-type: none"> — Document survey <ul style="list-style-type: none"> — Drainage outlet position — Effluent type — Confirmation of the survey date and point (map) — Sampling method / analysis parameters 	<p>Ambient air survey</p> <ul style="list-style-type: none"> — Select the point (What is it representative of?) — Understanding generating sources around the survey point — Confirm survey date and site (map) — Sampling method / survey items — Storage of samples — Number of measurement times / analysis items <p>Flue gas survey</p> <ul style="list-style-type: none"> — Document survey <ul style="list-style-type: none"> — Check the measuring hole — Type and scale, etc., of emission source — Results of measurements by factory — Safety check of sampling site — Survey date / survey target / document survey — Sampling method / analysis items
Preparation of Survey	<ol style="list-style-type: none"> 1) Prepare equipment/materials, vessels, and field notes in accordance with the items to be surveyed. 2) Classify and prepare vessels per survey point. 3) Map and camera 	<ol style="list-style-type: none"> 1) Prepare equipment/materials, vessels, and field notes in accordance with the items to be examined. 2) Setup weighing of the filter paper, etc. 3) Tests must be carried out to ensure that the sampling equipment is working properly.
Survey Date	<p>River and sea water survey</p> <ul style="list-style-type: none"> — Record the weather of the day before and upstream — Check the water level — Record any peripheral situations such as construction work — Check the tide table in affected areas <p>Factory effluent survey</p> <ul style="list-style-type: none"> — Record the appearance of the effluent 	<p>Ambient air survey</p> <ul style="list-style-type: none"> — Meteorological conditions (weather, temperature, wind direction and velocity) — Record any peripheral situations around the survey site <p>Flue gas survey</p> <ul style="list-style-type: none"> — Operating status of the facility (fuel usage volume) — Flue gas temperature — Volume of gas emitted
Execution	<ol style="list-style-type: none"> 1) Care must be taken when washing equipment and vessels with solution. 2) Check the sample containers 3) Check storage of water samples and its preparation 4) Clearly describe the sampling position. 5) Record the sampling time 	<ol style="list-style-type: none"> 1) Warm up the sampling equipment. 2) Washing the sampling bag with solution. 3) Clearly describe the sampling site. 4) Record the sampling time and volume.

1.3 Notes on Handling Accidents

Preparation on the assumption that an accident may occur is required as they tend to occur suddenly. In the event of an accident, check the current status in accordance with the table below, and plan, prepare, and conduct the required sampling to determine the cause(s) and draw up countermeasures.

	Many fish are floating in the river	Visible gas emission	Coughing or breathing difficulties
Information to be collected	<p>Field information</p> <ul style="list-style-type: none"> └ Floating position └ Size and numbers of fish └ Water level of the river └ Abnormalities in the river └ Are fish floating continuously? 	<p>Field information</p> <ul style="list-style-type: none"> └ Gas emission position └ Color of the gas └ Are birds flying on the downwind? └ Wind direction └ Smell 	<p>Field information</p> <ul style="list-style-type: none"> └ Site of breathing difficulties └ Appearance of people in the area └ Existence of chimneys └ Smell └ Has emission of gas stopped?
Sampling to determine cause(s) and draw up countermeasures	<p>Estimate of cause</p> <ul style="list-style-type: none"> └ Water level and temperature └ Death in large numbers └ Information on local factories <p>Items taken for field checks</p> <ul style="list-style-type: none"> └ Field note └ Poly bottles └ pH test paper └ Bag for fish └ Poly buckets └ Camera <p>Survey conducted by a number of groups</p> <ul style="list-style-type: none"> └ Check floating fish └ Check water levels └ Investigate local factories <p>Caused by insufficient of dissolved oxygen</p> <ul style="list-style-type: none"> └ Water thermometer └ Compact pH meter └ Sample bottle for DO <p>Caused by foreign matter such as poison</p> <ul style="list-style-type: none"> └ Water thermometer └ Compact pH meter └ Sterilized bottles └ Glass bottles └ Amber colored glass bottles └ Preparation chemicals for the samples containing metals └ Water sampler 	<p>Estimation of causes</p> <ul style="list-style-type: none"> └ Gas emitting site └ Color and smell of gas └ Information on local factories <p>Items taken for field checks</p> <ul style="list-style-type: none"> └ Field note └ Compact gas detector └ Sampling bag └ Compact pump └ Camera └ Transceiver └ Gas mask 	<p>Estimation of causes</p> <ul style="list-style-type: none"> └ Site of breathing difficulties └ Appearance of people in the area └ Smell <p>Items taken for field checks</p> <ul style="list-style-type: none"> └ Field note └ Compact gas detector └ Sampling bag └ Compact pump └ Camera └ Transceiver └ Gas mask

2. Sampling of Water

2.1 Survey Planning

2.1.1 Factors must be considered for survey

Three factors, namely, 'why', 'what', and 'how' must always be considered when conducting a water quality survey.

1) 'Why': Survey objective

Surveys must be planned in accordance with the objective, as the sampling frequency / number of times, survey sites, and measurement items differ depending on why the water quality is to be examined.

2) 'What': Survey target

Concentration of water components and coexistent substances differ according to whether the target is a river, lake/pond, underground or marine, as well as various water types for utilization or drainage, etc. There are also individual characteristics in those fluctuation and distribution patterns of water quality. The characteristics of the targeted water should be sufficiently understood and an appropriate sampling plan drawn up with due consideration for the survey objective and method (in particular, the items to be measured and analysis method). Furthermore, the condition of the targeted water area must be considered as well as general differences and characteristics.

3) 'How': Survey method

Related to the above 2), a quantitative method must be selected in accordance with the targeted water, and a plan must be drawn up to implement the required pretreatment. The quantitative method may be selected with consideration for operational speed and simplicity in accordance with the precision required, which will itself depend on the survey objective. Continuous measurement and automatic analysis may also be considered depending on the sampling requirements.

The following factors are considered necessary to draw up a water quality survey plan.

- (a) Selection of a survey site
- (b) Survey section
- (c) Survey period
- (d) Survey frequency
- (e) Sampling method
- (f) Storage and pretreatment of samples
- (g) Water analysis procedure (Measurement items and analysis method)
- (h) Collection of data concerned

Actual restrictions must also be considered, so how to narrow the gap between ideal and realistic

plans is important when drawing up an appropriate survey plan. The following are issues that need to be considered.

- (i) Status of the survey site
- (ii) Water sampling method
- (iii) Transportation means, transport facilities
- (iv) Volume of water samples and number of vessels
- (v) Investigators, and their experience and technical levels
- (vi) Survey expenses

When a water quality survey is first conducted in an area, the condition must be known sufficiently by carrying out a pre-survey.

For example, as regards (i), there are many unclear issues when looking at the map, such as how to get to the survey site, its peripheral status, piping/drainage channel at the predetermined site, etc., so field checks must be carried out.

Regarding (ii), there are several issues to be addressed, such as whether or not water can be collected directly, what kind of water samplers can be used, and whether there is any usable water craft related to flow velocity and water level must be confirmed as well.

When surveys on water are conducted for industrial water, industrial wastewater, tap water and sewage for management purposes, it is important to understand the characteristics of the targeted water, existence of the treatment facility, and status of water in the area.

In particular, (a) Selection of the survey site, (b) Survey section, (c) Survey period, and (d) Survey frequency, are explained in following section.

2.1.2 Selection of the survey site

Selection methods of sites for water quality survey on rivers, lakes/ponds, and in the sea, and survey of water management for utilization/drainage, and pollution status are listed in Table 2.1 'Selection of Survey Sites'.

Table 2.1 'Selection of survey sites'

Waters	General water quality survey	Survey into water quality for utilization / drainage and pollution
Rivers	<ul style="list-style-type: none"> 1) Sites along the main rivers and its tributaries upstream of their confluence, and other sites downstream where the waters are sufficiently mixed. 2) A site close to the mouth of a river 3) When there are dams and lakes, select sites up- and downstream of them. 4) If there is the possibility that abnormal water is flowing, select sites up- and downstream of the suspected cause 	<ul style="list-style-type: none"> 1) Water utilization site 2) A site in the drainage system, and sites before and after the mixing of effluent.
Lakes/ Ponds	<ul style="list-style-type: none"> 1) Center of the lake 2) Site where water exits into a river 3) A site in the entry river, and another after the water is well mixed 	<ul style="list-style-type: none"> 1) Water utilization site 2) A site in the drainage system, and a site after the mixing of effluent.
Sea	Select sites with due consideration for the shape of the water area and the river water flow status.	Select sites with due consideration for the shape of the water area, ocean currents, tides, water utilization status, and the positions of primary sources of pollution.

2.1.3 Survey sections

(1) Rivers

Make a decision with due consideration for the uniformity of the water quality at the sampling site and the survey objective.

1) Representative water quality

It is considered that sampling in the maximum-depth-stream (the area of the river with the maximum cross-sectional flow rate) is generally best to determine the representative water quality. However, it takes much time and effort to find the maximum-depth-stream through detailed measurements of the flow velocity distribution, and such accuracy is not strictly required. Thus, it is normal to determine the quickest flow area by sight and sampling the water surface. Although there is a method involving sampling at a depth 20% from the surface (examination method for public waters specified by the Environment Agency of Japan), it is actually rather difficult to sample water at a depth 20% from the surface in such narrow areas, so using a bucket or suchlike to sample the surface is sufficient.

2) Heterogeneous water quality

When water quality differs depending on its depth and position in the cross-sectional direction of the river, take water samples at various positions in accordance with the objective, and carry out analysis on individual or mixed samples accordingly.

For example, water quality may be heterogeneous in positions where effluent is not well mixed or if there is a branch stream of different water quality. It is not necessary to conduct a survey of typical water quality as mentioned in 1) at such a site, but if there is no other suitable survey site, a survey on mixing and diffusion must be conducted, although sampling the water and analysis are troublesome. When it is thought likely that water quality is heterogeneous, it is better to determine the sampling site after measuring the temperature, pH, electrical conductivity, and amount of dissolved oxygen to check uniformity.

(2) Lakes/Ponds

Water sampling sites must be decided with consideration for differences in water quality due to depth. Thermoclines are found in temperate zone lakes during summer and winter which prevent the mixing of upper and lower water layers and often result in some unique characteristics in the vertical distribution of the water quality. In this case, water below the thermocline must be sampled as well as surface water.

When operating in subtropical zones with both dry and rainy seasons, it is necessary to conduct water sampling during both seasons to understand the workings of the vertical distribution. A unique characteristic in water quality is sometimes seen with bottom layer water due to deposit and decomposition of suspended solids, and elution from bottom sediment. In particular, sampling of bottom layer water and

water near bottom sediment is also important when conducting surveys with consideration for organic impurities, eutrophication, and the behavior of heavy metals. The important sites are summarized as follows.

- 1) Single-site water sampling: Sample the surface water.
- 2) Double-site water sampling: Sample the surface and bottom layer waters.
- 3) Vertical distribution of water quality: Measure the vertical distribution of water temperature, pH, electrical conductivity, and dissolved oxygen, and sample water in at least three sites in accordance with the stratification.
- 4) Survey in accordance with water utilization purpose: Sample the water in accordance with where it is taken from when conducting water quality surveys related to water utilization, such as water for agricultural and industrial use or as a water supply.

(3) Sea

Seawater sampling sites are shown in Table 2.2 as an example of the sampling methods for seawater quality mainly along the coastline.

Table 2.2 Seawater sampling sites

Sea depth	Sampling depth
<5m	0.5m below the surface
5~10m	0.5 and 2 m below the surface
>10m	0.5, 2, and 10m below the surface

0.5, 2, and 10m below the sea's surface are sometimes referred to as the top, middle, and bottom layers regardless of the depth of the water, so care must be taken when displaying the results. Also, water should be sampled at relevant depths in accordance with each objective for various research-related surveys.

2.1.4 Survey period

(1) Rivers

- 1) Select a day with stable water quality after a spell of relatively good weather to determine the general condition of the water quality.
- 2) Periodically collect regular water samples when carrying out consecutive surveys throughout the year.
- 3) Choose an survey period in accordance with the water utilization status when carrying out a water quality survey for water utilization.

(2) Lakes/Ponds

- 1) Conduct surveys in each season to determine the general condition of the water quality.
- 2) Stagnation period must be considered important when examining eutrophication.

- 3) When the effects on water temperature and turbidity in manmade lakes with dam are considered important, surveys are also conducted on related rivers including the season when they are swollen.

2.1.5 Survey frequency

Fluctuation patterns of water quality in the targeted water area are explained as examples.

- 1) Daily fluctuation pattern example

Periodic daily fluctuations may be seen in rivers into which urban sewage and factory effluent flow. In this case, frequent water sampling is required to determine the representative water quality and outflow load.

- 2) Monthly fluctuation pattern example

Frequent sampling is required for suspended solids (SS), which fluctuates in relation to the flow rate, rain status, and various basin factors, as the fluctuation pattern may not be clearly understood through monthly measurements alone.

- 3) Examples of fluctuating water quality due to rising water

When water quality must be considered in relation to the outflow mechanism for various chemical components, a number of water samples must be taken at short intervals in the initial stages of rain fall, particularly when any such rise is due to rainwater.

2.2 Types of Sample Containers

Normally, polyethylene or colorless glass bottles with ground stoppers are used as sample containers. Samples should not become contaminated and the components targeted for testing should not be allowed to escape from the sample in the containers, so it must be made of a quality material and it should be possible to close it securely. They should only be used after being sufficiently rinsed to avoid any impediment to testing. Rubber and cork stoppers must not be used to avoid the risk of contaminating the sample.

Each material has the following advantages and disadvantages.

2.2.1 Poly bottles (polyethylene, polypropylene, etc.)

Colorless bottles must be used. Their shock resistance, lightness, and superior chemical resistance make them popular. They come in varying degrees of toughness, from hard to comparatively soft, and generally such materials are considered not to virtually elute. However, catalytic molybdenum, chrome, and chitin used during their production become slightly eluted in some products, so care must be taken with the usage objectives. Colored ones are unsuitable.

Care must be taken when using poly bottles to store samples for long term as they are opaque, have weak heat resistance, and are not airtight, so microorganisms and algae are easily propagated.

Typical mineral water bottles (polyethylene terephthalate (PET) bottles) can also be used, but great care must be taken with their use as they are thin and easily damaged if scarred. Other bottles that were used for juice, coffee, or tea are not suitable as it is difficult to clean them of adhered components thoroughly enough.

Polyethylene bottles have a tendency to adsorb phosphorus compounds, organic matter, and heavy metals, etc. from samples. The adsorption of heavy metals can be prevented during storage by adding nitric and hydrochloric acids.

Rinsing bottles

Prior to their usage, rinse them first with tap water and then with distilled or ion exchange water. When testing for trace amounts of metals, rinse them with warmed nitric acid (1+10) or warmed hydrochloric acid (1+5), then with tap water again, and finally rinse them out with distilled or ion exchange water.

When used bottles are re-used, rinse them with warmed nitric acid (1+10), warmed hydrochloric acid (1+5), or medical rinsing liquid such as a surface-active agent, rinse them again with tap water, and finally rinse them out with distilled or ion exchange water. When some matter is adhered, use a brush with cleanser or something suitable to give it a pre-wash before taking the above action. (Soaps are not suitable as they are liable to remain inside the bottle.) Cleansers that include components being targeted in the test should not be used.

2.2.2 Glass bottles

These are widely used as sample containers, and have a number of advantages such as little deterioration of samples and ease of observation. However, they are inconvenient when transporting a large amount of samples, as they are easy to break.

There are two types of glass, namely hard and soft. Hard glass bottles blown with mold is generally used for sample containers. Either wide- or narrow-mouthed bottles can be used, but bottles whose inner shoulder curves are easy to clean are most suitable. Alkaline elements, such as sodium, potassium, silica, and boron are easily eluted from new bottles. Arsenic, zinc, antimony, and lead may be eluted from some products. In particular, boron is eluted from hard glass bottles, so soft glass products must be used for boron-related tests. Examples of the chemical composition of such glass are shown in Table 2.3.

Table 2.3 Example of the chemical composition of glass (%)

	Soft glass	Hard glass
SiO ₂	71.3	80.5
Al ₂ O ₃	1~3	2.0
Na ₂ O	13.4	4.4
K ₂ O	1	0.2
MgO	0.3	0.1
CaO	12.5	0.3
B ₂ O ₃	~	11.8
As ₂ O ₃	0.01	0.3
Fe ₂ O ₃	0.01	0.04

Prior to use, they should be sufficiently rinsed in the same way as poly bottles. When glass bottles are reused, foreign matter attached to the inside of the glass must be removed and, depending on the type of foreign matter attached, it should be cleaned with a mixed solution of nitric acid and hydrogen peroxide (3 parts nitric acid (6N): 1 part hydrogen peroxide solution (30w/v%)) before rinsing.

Amber-colored bottles that cut out light should be used for samples when measuring components that are liable to photochemical or photolysis reactions such as agricultural chemicals, organic chemical components, and nitrite ions. Alternatively, bottles should be wrapped with shade paper or put in a shade bag and placed in a refrigerated box for transport to a laboratory, after which measurements should be carried out as soon as possible.

2.2.3 Others

Beer bottles, Japanese sake bottles, and bottles wound with rattan are made of soft glass whose components elute easily, and it is anticipated that such bottles are very contaminated making them difficult to clean sufficiently. Thus, it would be better not to use such containers.

It is sensible to take extra sample bottles in case you collect more water samples than planned for water quality survey. Additional polyethylene bags as well as such bottles are convenient for unexpected water samples.

2.3 Various Types of Water Sampler and Usage

The most suitable water sampler should be used in terms of the survey objective and field status. Typical water samplers are described as follows.

2.3.1 Sampling using sampling vessels (surface water sampling)

Rinse the sampling vessel with water on site 3~4 times. Care must be taken to avoid contaminating water to be sampled during rinsing.

Submerge the sampling vessel gently, fill it with the water sample and close it tightly. If the collected water sample may be frozen, leave some space for expansion equivalent to about 10% of the sampling vessel.

2.3.2 Surface water sampling using buckets or samplers with shafts (scoops)

Such instruments made of polyethylene are often used. A rope can be attached to the bucket if required. Scoops with adjustable shafts are convenient. Items made of synthetic resins such as polypropylene can also be used. Samplers made of stainless steel can be used provided they are not to be used for tests on trace amounts of heavy metals. An example of a water sampler with shaft is shown in Figure 2.1.

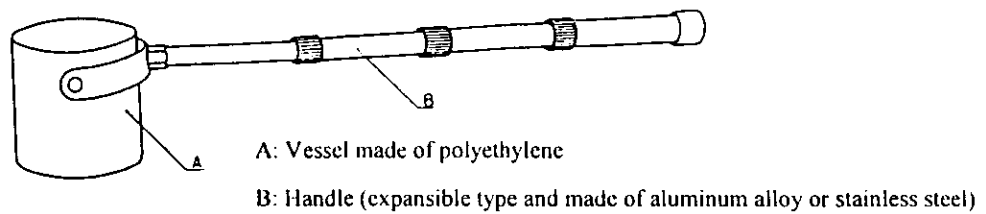

Figure 2.1 Example of long handle water sampler

Procedure:

Rinse the sampler with water on site. Next, scoop up some water at the sampling site, quickly rinse the sample container with it, then fill them with the water and close it tight. When sampling water with substantial amounts of suspended solids, pour it quickly into the sample container while mixing it sufficiently to ensure uniformity.

2.3.3 Water collection using Heyroth water sampler

Water can be sampled at various depths from water storage tanks, waterways, rivers, lakes, wells, and the sea using this water sampler. It is generally used to sample water up to depths of 10m.

However, the water samples replace air within the sampling vessel, so this method is not suitable for sampling a thin stratification as the water is agitated during sampling. Also, the sample comes into contact with the air, so it is not suitable for certain test samples such as for dissolved oxygen or reductive substances.

The sampling vessel is attached to the frame with a weight, and the vessel's stopper is removed at the required depth to obtain the water. 500 ~ 1000ml capacity vessels are generally used. An example of a Heyroth water sampler is shown in Figure 2.2.

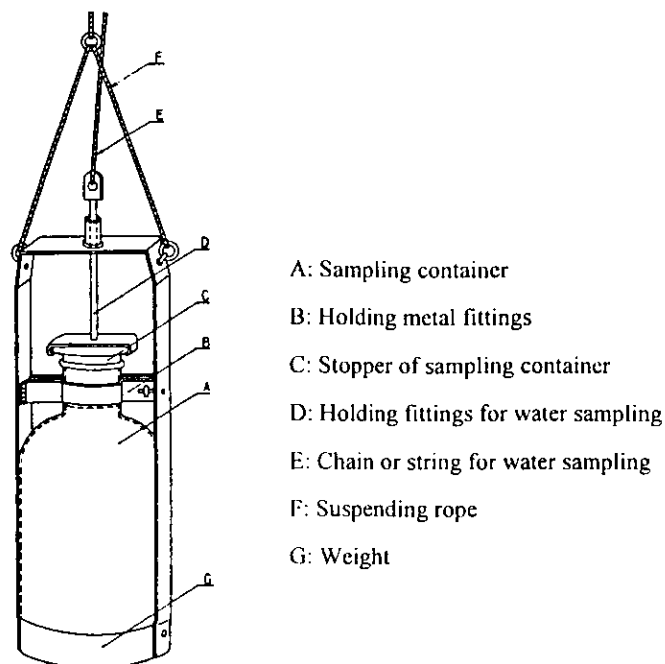

Figure 2.2 An example of a Heyroth water sampler

Procedure:

Make sure there are no malfunctions with the Heyroth water sampler, suspension rope, and chain to open the stopper, etc.; attach a sampling vessel that has already been rinsed with water into place, and secure it to the metal frame.

Gently sink the water sampler to the appropriate depth using the suspension rope, and confirm the depth of the water. Pull the chain or rope to open the stopper and leave it to fill with water. Release the chain or rope to close the stopper, raise the water sampler, remove the sampling vessel, and close it tightly.

Refer to the manual for detailed handling of the sampler. Mark the suspension rope at each depth before sampling. Care must be taken that the rope and so forth do not pollute the water at the sampling area. It is better to secure the suspension rope so as to prevent losing the water sampler in the water.

Simple water sampler

Simple water sampling bottles with weights on the sampling vessels are shown in Figures 2.3. Water is sampled by pulling the water sampling string and removing the rubber stopper or the soft vinyl chloride tube. Care must be taken not to disconnect the sampling vessel when removing the stopper as it comes out easily if not securely fixed to the vessel with a suspension rope with weight.

An appropriately sized cleaned stone that is placed and suspended in a synthetic resin net can be used as a 'weight'.

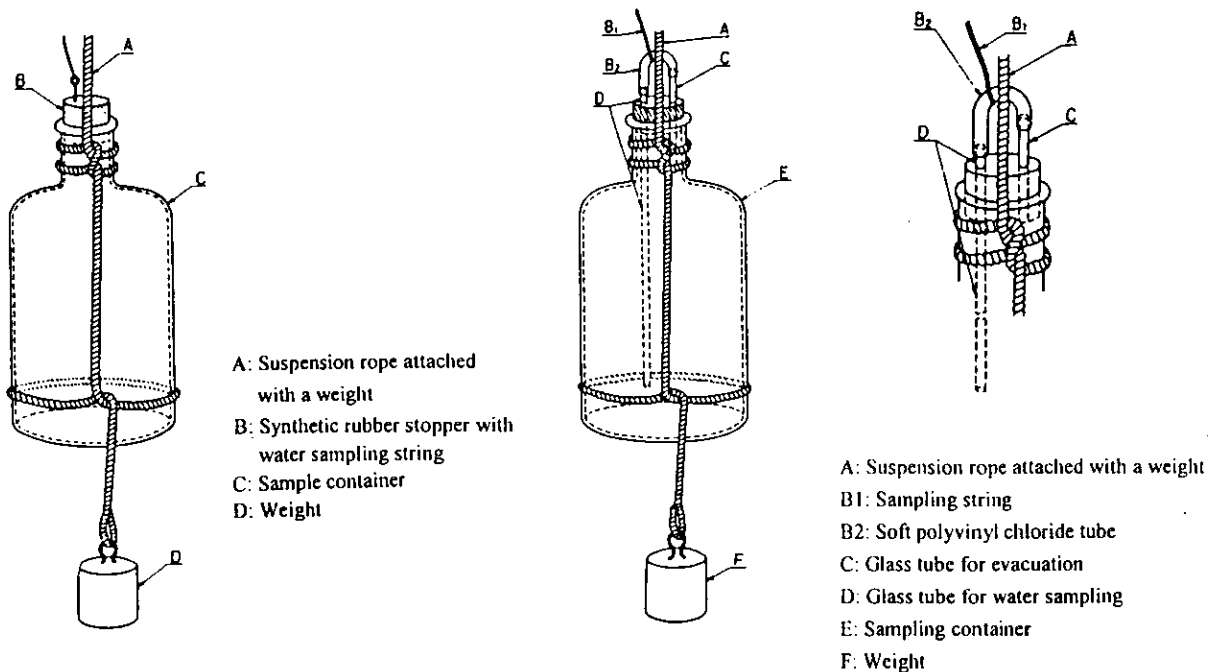

Figure 2.3 Examples of water sampling bottles using sample containers

2.3.4 Vandorn water sampler

Samples water at different depths in water storage tanks, waterways, rivers, lakes, wells, and sea. Synthetic rubber lids are attached to the top and bottom of the synthetic resin cylinder. There are two types, one of which is opaque and made of polyethylene and the other which is clear and made of acrylic resin or polycarbonate. The cylinder capacity varies from 1 to 20 liters.

An example of a Vandorn water sampler is shown in Figure 2.4.

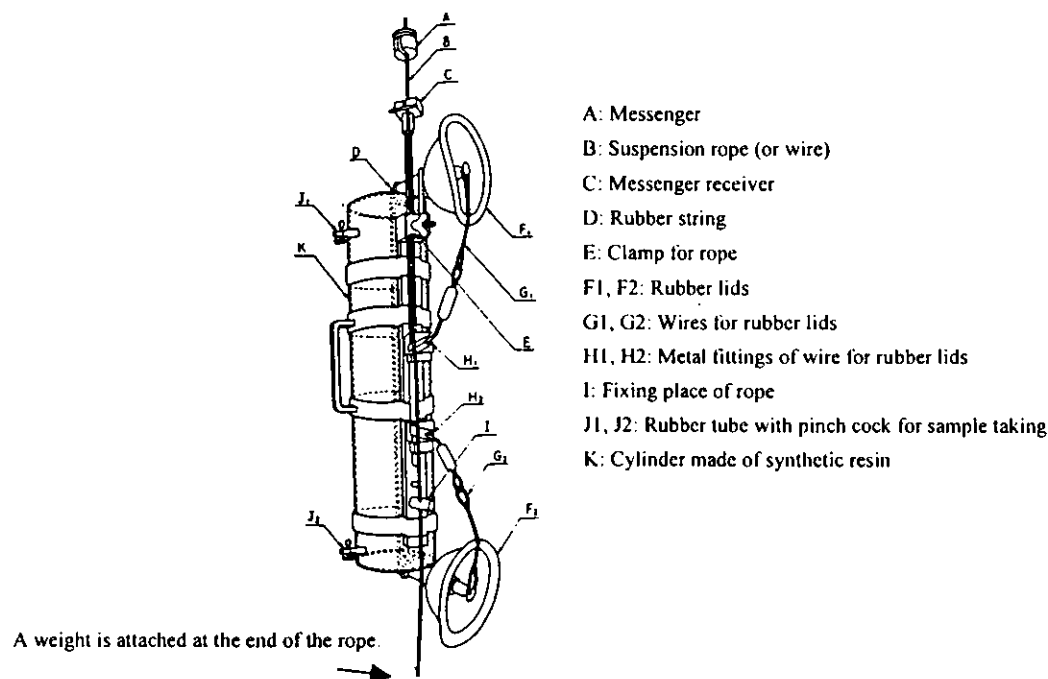

Figure 2.4 An example of a Vandorn water sampler

Procedure:

Check that there are no malfunctions with the messenger receiver, lids at either end, wires for the rubber lids, and suspension rope, etc of the Vandorn water sampler. If the spring on the messenger receiver has been weakened, the cylinder lid may close during sampling, so make sure it is strong enough.

Rinse the water sampling cylinder, top and bottom lids, and bucket to be used, etc., with water on site before sampling.

Attach the top and bottom lids with the wire metal fittings.

Gently sink the Vandorn water sampler to the appropriate depth using the suspension rope, and confirm the depth of water.

Move the Vandorn water sampler up and down two or three times to ensure the water within the cylinder is sufficiently exchanged, drop the messenger, close the lids at top and bottom of the cylinder, and sample the water. In this case, the sampler is moved up and down at the appropriate depth of water, so it is unsuitable for sampling thin stratification of water.

Pull up the Vandorn water sampler, open the (soft) vinyl tube with the pinch cock to allow in the water sample to pour some of the water sample in the cylinder out into the bucket to rinse it, before transferring the rest of the water sample to the bucket.

Rinse the sampling vessel with the water sample once or twice while mixing it, and then fill it with the water sample.

When measuring dissolved oxygen within the collected sample, attach the soft vinyl chloride tube to the nozzle of the water sampler, insert it so that the end of the vinyl tube reaches the bottom of the sample bottle for measuring dissolved oxygen (dissolved oxygen bottle), and pour in the water sample. Allow it to overflow by approximately 50% of the sample bottle volume, and make quick measurements through appropriate pretreatment for dissolved oxygen or by using a DO meter.

If the sample has many suspended solid, it should be handled carefully as sediment may settle on the bottom of the cylinder.

Refer to the manual for details on handling the sampler.

2.3.5 Insulated water sampler

Insulating material is used around the water sampler to keep the temperature of the collected water as near as possible to that when it was collected, and its field operability is superior. There are two types, one of which seals the sample by dropping the messenger and lowering the lids and cylinder after the water sampler is sunk to the appropriate depth by the messenger, while the other operates by closing the upper and lower lids tightly.

Figures 2.5 show examples of insulated water samplers.

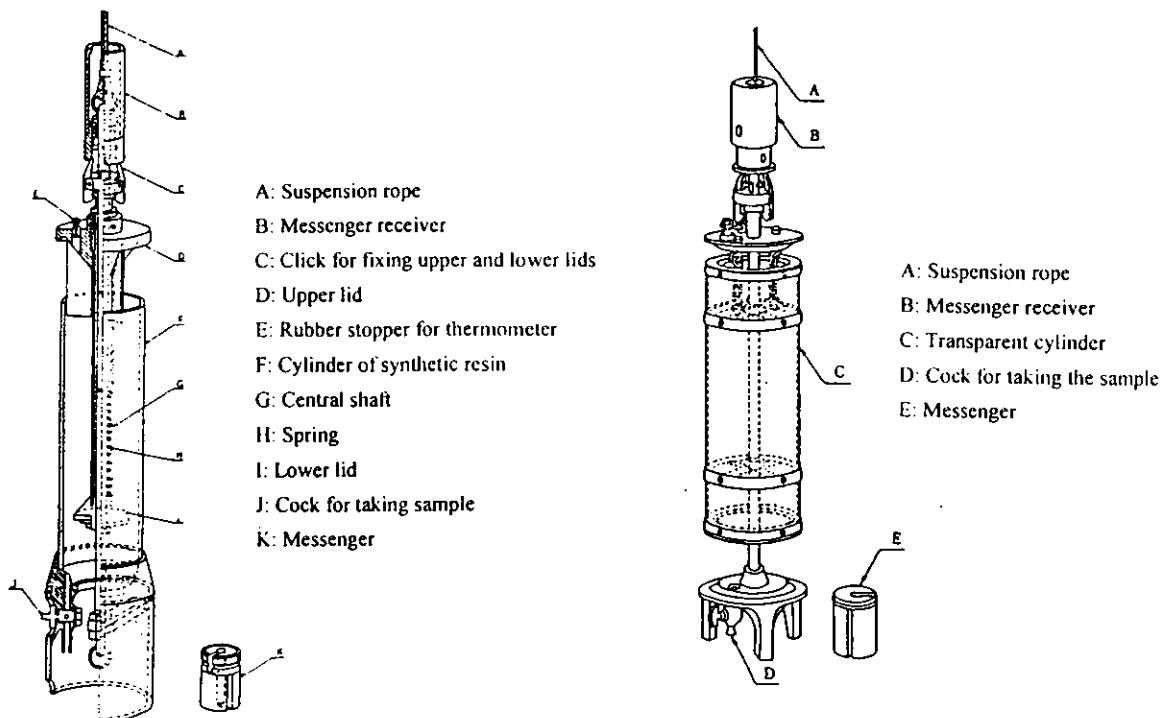

Figure 2.5 Example of an insulated water sampler

This water sampler is not as good at allowing the water in or out due to its structure, so move the sampler up and down a few times at the prescribed depth before sealing it to collect the water sample to facilitate exchange of water within the cylinder. As a result, water is mixed and sampled at a depth that ranges by 60cm or more, making it unsuitable to sample water in thinner stratifications.

The water temperature can be checked by inserting a mercury thermometer into the opening. A sampler has been produced to minimize any water sample temperature changes by insulating the cylinder with thick synthetic rubber, etc, and this is used when measuring the water temperature is also important, such as with well water.

Comply with the Vandorn water sampler described before for general operational details and how to clean the sampler.

2.3.6 Other methods

Using an underwater pump:

There are a variety of pumps ranging from large types for construction to small types for domestic use. Those with a water pumping capacity of between a dozen and several tens of liters and a pumping capability of approximately 2m-aq are suitable for use when water sampling. Domestic versions used for pumping bath water can also be used. Most domestic types operate on 6~12V DC, are light, simple, and easy to use as they can be powered by a car battery in the field. In this case, vinyl piping, etc., must be used as the water conduit, and it must be cleaned and checked prior to use as it easily becomes contaminated by organic matter and algae, etc., attached inside the pipe.

Other:

Furthermore, sampling can be done using siphon action by taking advantage of the difference in depth of the water surface and the bottom of the observation boat, and other methods involving collecting water by suction using small vacuum pumps for experimental use into sample bottles.

Sites to note when sampling flowing water

Adequate consideration is required in accordance with the field conditions when sampling flowing water such as in rivers or canals as the water sampler is easily displaced and it is difficult to sample water at the prescribed depth.

Certain techniques are required such as tying the boat to a bridge support or tree on the riverbank using a rope or dropping an anchor to prevent drifting due to winds or currents when sampling water from an observation boat.

Water must be sampled from a position where the propeller and steering of the boat are not effected by ropes or cables when using the water sampler or other observation machinery and materials. Around the prow of the boat is normally considered appropriate.

If the water sampler is subject to drift due to the current and can not be kept at the prescribed depth, tie the sampler to a straight pole, and sample the water by lowering it vertically to the prescribed depth from the boat. In this case, it is convenient to use a pole with measurement markings to show the depth. (A flat disk is

attached to the bottom edge, the pole is marked every 10–20 cm and different colors are used for each section. A number of poles can be used as a set, and screwed together.)

An example is shown in Figure 2.8.

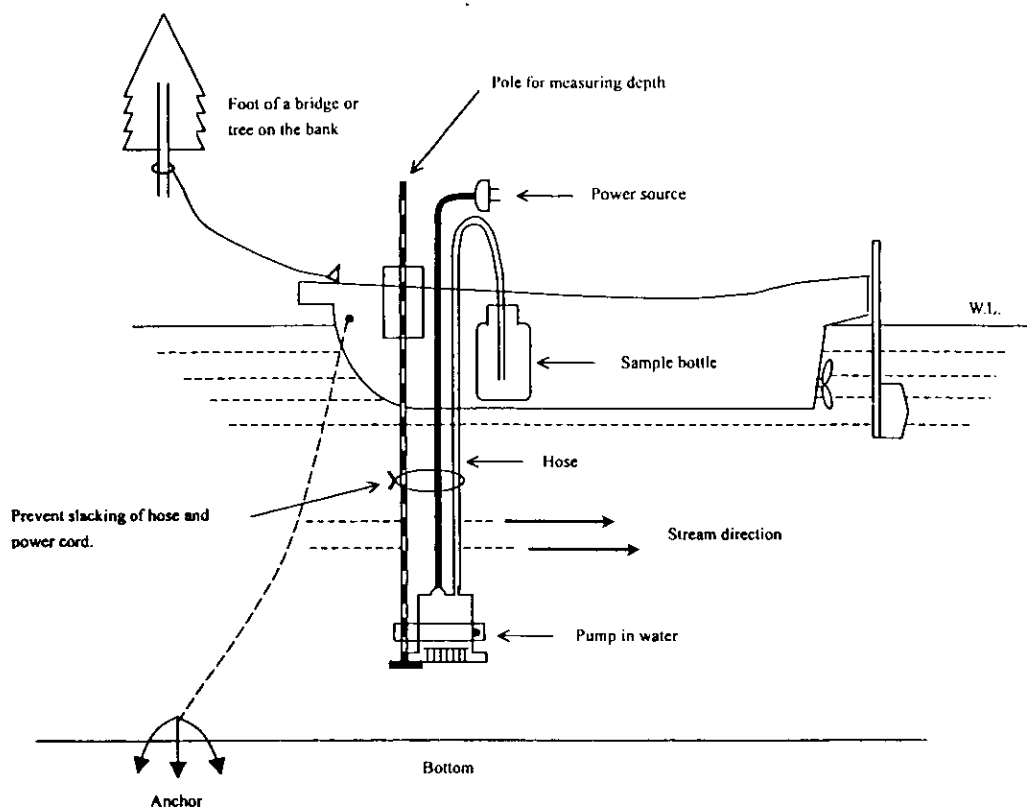

Figure 2.8 Example of sampling flowing water

2.4 Sample Water Storage Method

If the planned water quality items can be measured in the field, misjudgments caused by changes in the water quality due to the passage of time can be avoided. However, it is still normal to carry out measurements in a laboratory after conducting minimum measurements in the field and taking samples back as there are many restrictions, such as conditions at the measuring site, delivery of the measuring equipment, and survey schedule.

In this case, appropriate action should be taken to preserve the samples. Generally, they are refrigerated, have chemicals added, or have their pH adjusted, depending on the test procedure for each parameter, to control the hydrolysis and volatility of the chemical compounds and biological activity.

The sample water volume required differs according to the analytic method and concentration of the targeted components, so the required volume for each survey item should be considered and determined beforehand.

As a general rule, collected samples must be saved in accordance with the method that has been officially specified per parameter. Sites to note for preserving sample water per parameter are listed with

reference to the JIS and standard methods in Table 2.4. For other parameters, sample should generally be stored in a cool, dark place between zero and ten degrees centigrade.

The general standard of required water sample volumes is shown.

Table 2.4 Sites to note for preservation of sample water

Test items	Water sampling bottle	Required water sample volume (ml)	Preparation and safekeeping method
Smell	G	500	Fill a glass bottle with a ground stopper, store it in a cool, dark place at 4°C, and conduct measurements as soon as possible.
Color	G	200	Measurements should be conducted immediately as it is easily changed due to physical and biochemical reactions.
Turbidity	P, G		Store it in a cool, dark place at 4°C and carry out measurements within 24 hours. Vigorously shake it before measurements.
Alkalinity and acidity	P, G (B)	200	Fill the bottle, tightly close the lid, store it at 4°C and carry out measurements within 24 hours. Do not stir the sample or leave it in contact with the air to avoid any reactions such as with carbonic acid.
Suspended solids (SS), total dissolved solids (TDS) and total evaporation residue (TR)	P, G (B)	500	Quickly filter, separate and measure. TDS and TR increase if stored in a soft glass bottle. When iron or manganese is included, close the lid tightly to avoid any exposure to the air, and store it in a dark place at 10°C or lower (but without freezing).
BOD	P, G	1000	Store it in a cool, dark place at between 0°C and 10°C. Testing should be carried out as soon as possible.
COD	P, G	100	Store it in a cool, dark place at between 0°C and 10°C. Measurements should be carried out as soon as possible.
TOC, TOD	G (amber colored), P	100	Store it in a cool, dark place at 10°C or lower.
Hexane extracts (oil content) Non-volatile mineral oils / Animal and vegetable oils	G (S, Wide-mouthed bottle)	5L ~ 10L	Fill a wide-mouthed bottle with a ground stopper, which has been sufficiently rinsed with N-hexane, with the water sample leaving sufficient space at the top. Use the whole amount for measurement and do not transfer or separate it. If it must be stored or transported, add methyl orange indicator, then add hydrochloric acid (1+1) until the sample water turns red, and close it tightly.
Carbon tetrachloride extracts	G (S, wide-mouthed bottle)	1000	Treat in the same manner as hexane extracts
Phenols	G	500	Add phosphoric acid until the pH = 4. Add copper (II) sulfate pentahydrate (1g) per liter of sample, shake it and store it in a cool, dark place at between 0°C and 10°C.

G: Glass bottles, P: Poly bottles

(A): washed with acid, (B): borosilicate glass, (S): washed with organic solvent

For the parameters sensitive to photochemical reactions, samples should be kept in amber-colored glass bottles or covered with black boxes.

Test items	Water sampling bottle	Required water sample volume (ml)	Preparation and safekeeping method
Nitrogen (1) Nitrite ions	P, G	100	Store it in a cool, dark place at between 0°C and 10°C. Measurements should be carried out as soon as possible. If it is stored for around three days, add 1ml chloroform per liter of sample and store it in a cool, dark place at between 0°C and 10°C. Immediate measurements should be carried out when ion chromatography is used without being stored.
(2) Nitrate ions	P, G	100	Measure immediately. If this is not possible, add hydrochloric or sulfuric acid to the sample until the pH = 2~3, and store it in a cool, dark place at between 0°C and 10°C. Immediate measurements should be carried out when ion chromatography is used without being stored.
(3) Ammonium ion	P, G	500	Measure immediately as it is easily changed. If this is not possible, store it in the same way as nitrate ions.
(1) Phosphorus Phosphorus Compounds	G (A)	100	When fractional determination is carried out per phosphorus type, filter the sample water immediately after collecting it in accordance with the targeted. Add approximately 5ml of chloroform per liter of the sample while it is neutral, and store it in a cool, dark place at between 0°C and 10°C. Under such conditions, it can be saved for 1~2 days.
(2) Total phosphorus (T-P)	G (A)	100	These can be preserved by adding sulfuric or nitric acid until the pH = around 2.
(3) Dissolved phosphorus	G (A)	100	Filter the sample water using 0.45µm or No. 5C filter paper immediately after collection, add approximately 5ml of chloroform per liter of the sample and store it in a cool, dark place at between 0°C and 10°C. Under such conditions, it can be saved for 1~2 days.
(4) Phosphate ion	G (A)	100	As above
Dissolved oxygen	G (BOD bottle)	100~300	Measure immediately after the water is sampled, or carry out on-site preparation of the sample for preservation, store it in a cool, dark place at between 0°C and 10°C after closing it tightly, and measure it as soon as possible.
Residual chlorine	G	100	Measure immediately after the water is sampled. It can not be stored.
Cyanogen compounds	P, G	500	Add sodium hydroxide solution (20W/V%) until the pH = about 12 and store it. If oxidized substances such as residual chlorine exist, add L-ascorbic acid for reduction, and change the pH to about 12.
Sulfur compounds	P, G	200	These are classified per type, such as sulfide ions, sulfurous acid ions, and sulfate ions, etc. The processing and storage methods differ according to the analysis method that will be adopted.

2.5 Sample Transportation

Carry the sample water that has been collected in sample bottles. Great care must be taken concerning the following sites when sampling water.

- (1) Use appropriate sample bottles in accordance with the objective of quantitative survey. The bottles should be sufficiently rinsed out before use to avoid any contamination from the bottles themselves.
- (2) Rinse the sample bottle with a small amount of the sample water two or three times, gently then fill up with the water, and close them tightly.
- (3) If the sample water contains a lot of suspended solids, quickly pour the water into the sample bottle to ensure uniformity. Care must be taken to avoid any large pieces of matter, such as leaves or other bits off trees.
- (4) Pretreatment for sample preservation – as mentioned in Section 2.4 – must be carried out when storing samples in accordance with the parameter.
- (5) Place the label clearly describing the sample site, date and time on the sample bottle.

The sample water is normally carried to the lab by a water-sampling vehicle. Sites to note concerning the loading and transportation of the water samples by vehicle are described as follows.

- (1) When a number of analysis parameters are sampled simultaneously, classify the sample containers per analysis item as mentioned in Section 2.2 and load them.
- (2) It is convenient to use boxes with partitions for each parameters to prevent sample bottles falling over during transportation.
- (3) Use protective wrapping (synthetic resin net) to prevent damage due to contact with other vessels, and soft padding to cushion fragile vessels (such as glass ones) from shock.
- (4) For parameters that need to be kept cool against to temperature rises within the vehicle, (i.e. BOD, COD, bacteria, VOC, etc.), samples should be stored/transported in an ice box (cool box) with ice or coolants

Store the water samples that have been collected in a fridge or cold room. Although analysis must be carried out as soon as possible as a general rule, storage of certain parameters is possible by carrying out the appropriate procedure.

2.6 Field Note Description

When conducting sampling, also measure the air and water temperatures and note the outward appearance of the sampled water. In particular, components that easily decompose or react should be measured in the field or should be suitably prepared for storage. The instruments and reagents required for measurements when water is sampled are shown in Table 2.5.

Table 2.5 Measurements when sampling water

Items	Instruments and reagents
Outward appearance	Transparent glass bottle or beaker
Air and water temperatures	Mercury thermometer, thermistor
pH	pH colorimeter or pH meter
Transparency	Transparency meter Secchi plate
Turbidity	Turbidity meter
Electrical conductivity	Electrical conductivity meter
Dissolved oxygen	Dissolved oxygen bottle, reagent for the sample preservation, instruments or DO meter
Fe ²⁺	Reagents and instruments for absorption photometry Spectrophotometer (portable)
Sulfide ion	Reagents and instruments for sample preservation
Flow rate	Flow velocity meter and instrument to measure side cross-sections

Items to be measured in the field, instruments and reagents must be added in accordance with the objective of the survey. Some items may not be required depending on the target, such as rivers, lakes, underground water and seawater, so items to be measured in the field should be selected in accordance with the survey objective, and appropriate reagents and instruments selected. An example of a water-sampling diary is shown in Table 2-6. Sites to describe for the table are shown below.

- (1) Water sampling personnel: Water sampling is generally conducted in groups of two or more, so the names of all people concerned should be detailed.
- (2) Survey name: Describe the name of the survey.
- (3) River or factory name: Describe the items required in accordance with whether the target is a river, lake, underground water or sea, or the name of the source, such as factory.
- (4) Water sampling site: Clearly describe the name of the bridge for rivers, center or shore (i.e. dam site) for lakes, name of the well owner for underground water, name of the local coastline for seawater, and what kind of wastewater treatment is conducted for the effluent is discharged in the case of a factory. If it is a regular monitoring site or sites that have already been plotted on a map, the site reference number can be used for simplicity.
- (5) Water sampling time: Describe in hours and minutes.
- (6) Weather: Describe the weather on the day of sampling and one day before as clear, fair, cloudy or rainy, etc.
- (7) Outward appearance: Describe the degree of turbidity by eyesight when water is sampled. For example, if it is obviously turbid, use three categories such as 'Very', 'Somewhat' and 'Slightly', while if there are no apparent impurities, describe 'None'. It is preferable to describe the color of the water as well. 'Forel and Ule's color scale' is used as the international standard for the quality of the water's color. Water quality standard solutions can be observed in a total of 21 colors, comprising Forel (11 types) and Ule (10 types).
- (8) Air / water temperature: Use normal mercury thermometers to measure air temperatures in the shade. Also measure water temperature by immersing a mercury thermometer in the water sample until it

shows a constant value. Digital water thermometers that come with handy built-in pH meters can also be used.

- (9) Dissolved oxygen, electric conductivity, and pH: They must be measured and recorded if a convenient portable meter is available. It is also important to cross check the dissolved oxygen meter with a measured value of the sample using DO bottle.
- (10) River width and depth: Depths should be detailed in the case of rivers. If it is the first time the survey has been conducted at this site, estimate the width by counting the number of paces from one side to the other. The river depth is an important measurement item, so measure the depth with a weighted rope and record it. Also describe the depth at which each water sample is taken for vertical distribution surveys in lakes and the sea.
- (11) Flow velocity: Make a judgment on a five-point scale based on your visual observations. Floats can be used for instant measurements of the flow rate, so it should be measured when required. The following sites should generally be considered when selecting the location to measure flow velocity.
- Stream should flow through single channel.
 - Water should flow several times further than the river width (normally four times) in a straight line both up- and downstream, and there should not be a big difference in the cross section or inclination of the riverbed.
 - Poor condition riverbeds such as those with irregularly placed rocks and stones should not be selected.
 - Water streams should not be too fast or slow.
 - There should not be any whirlpools, backward flow, or stagnation.
- (12) Remarks: Describe any smells and changes in the environment (plants, waterfowl, etc.).

Table 2.6 Field note for water sampling

		Sampling personnel		Survey name		Day: Month: Year:		
				Sampling date				
River name / Factory name								
Sampling site								
Sampling time								
Weather	on one day before							
	on the day							
Outward appearance								
Air temperature /		/	/	/	/	/	/	/
Water temperature								
pH								
Dissolved oxygen (mg/l)								
Electric conductivity (μ /cm)								
River width (m)								
River depth								
Flow velocity								
Remarks								

3. Sampling of Ambient Air

Increased measurement accuracy is required for the air pollutants that cause acid rain such as sulfur dioxide, nitrogen oxides and photochemical oxidants, in order to achieve international consistency and global evaluations of concentration. As fluctuations in the flow rate have a significant effect on measurement accuracy when air is sampled, in particular, measurement accuracy has recently been improved through use of electric flow controllers such as mass flowmeters as well as the existing float flowmeter. Thus, general points to note when planning and carrying out sampling are described as follows.

3.1 Survey Plan

Normally, we need data on the relationship between pollutant concentration in ambient air and that at the emission source to survey environmental pollution. Air pollution concentration fluctuates in accordance with changes in the weather and emission sources, and the surveyed data also changes depending on the measurement device and person. It goes without saying that there should be minimal difference in data caused by measurement method. Measured data is significantly affected by the surrounding circumstances at the sampling site and changes in the weather, so a survey plan must be drawn up bearing such points in mind.

3.1.1 Selection of measurement point

Air pollutant concentration differs depending on the location and time. The measured value of each point must be representative of the peripheral air quality. However, pollutant concentration at each measurement point changes in accordance with the existence of local pollution sources, the peripheral natural environment (i.e. hills, trees, ponds, marshes) and the existence of manmade structures such as buildings and roads, and the height of the measurement point. Thus, measurement points should be representative of the area to minimize complications arising from the landscape and buildings, etc.

3.1.2 Installation height

Installation 1.5~2m above the ground is preferable when one considers the effect of air pollution on the human body and the area in which people are most active. However, the effects of buildings and such-like that exist at this level should be minimized as much as possible in towns crowded with buildings because the data may not be representative of the degree of pollution in the local area when the survey site is set up at ground level, as opposed to a flat site.

The air temperature should be measured at 1.2~1.5m, and wind velocity should be measured 6~10 m above the ground for weather observations. When gaseous pollutants are measured, follow the same procedure for air temperature measurements unless there is particularly strong gas adsorption on the ground. When high volume air samplers are used to measure particulate matter, dust fly up from the ground must be born in mind as well. Its installation must carefully be considered, especially when measurements are conducted on dry ground.

3.2 Flow Rate for Measurement of Ambient Air

3.2.1 Mass transfer measurement

Sampling the flow rate is most important when the pollutant concentration in the sampled air is measured using an automatic air-measuring instrument. Sampling involves the collection of targeted matter, while the sampling flow rate is required to obtain the transfer volume of the matter to be measured. Thus, when sampling is carried out, transfer volume of the targeted matter is obtained as dynamic or static flow rates using the sampling rate, collecting rate, and diffusion rate, etc.

3.2.2 Dynamic flow rate

Sampling flow rate can be obtained by the dynamic method using suction pumps, etc.

3.2.3 Static flow rate

When the vapor diffusion method for standard gas generation and molecular diffusion method for air sampling are adopted without using power such as a suction pump, mass transfer is obtained by the static method.

3.3 Flow Rate Measuring Instrument and Sampling Gas Flow Rate

When measuring air pollutant concentration, the air volume that is sampled together with the targeted components is measured. The flow velocity, volumetric flow, integrating flow (air volume), and pressure must be measured accurately as shown in Table 3.1.

Table 3.1 Measuring device for sample air volume

Measurement targets	Measuring instruments	Measurement range
Flow velocity	Pitot tube	5 m/sec or more
	Hot wire anemometer	0.05 ~ 40m/sec
Flow rate	Venturi meter	1 L/sec ~ 100m ³ /sec
	Orifice meter	1 cm ³ /sec ~ 100m ³ /sec
	Rotor meter (Float flowmeter)	0.01 cm ³ /sec ~ 50L/sec
	Mass flowmeter	0.2 cm ³ /sec ~ 400L/sec
Capacity (Volume)	Soap film flowmeter (Precision film flowmeter)	1 cm ³ /sec ~ 1000m ³ /sec
	Wet gas meter	Unrestricted
	Dry gas meter	Unrestricted
	Roots meter	Unrestricted
Pressure	Manometer	0 ~ 2 atm
	Aneroid pressure gauge	0 ~ 0.3 atm
	Brudon tube	0.2 atm or more

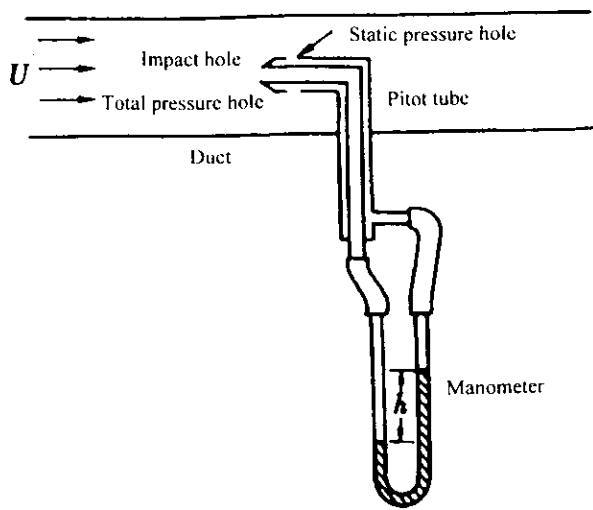

Figure 3.1 Pitot tube

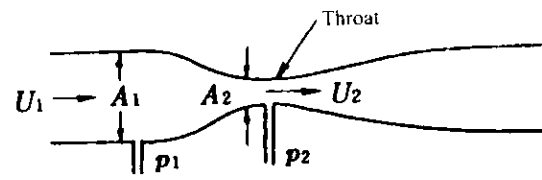

Figure 3.2 Venturi Meter

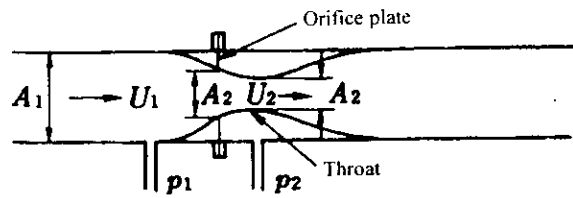

Figure 3.3 Orifice meter

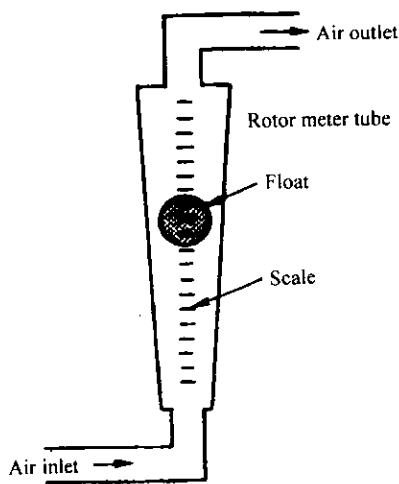

Figure 3.4 Rotor meter (float flowmeter)

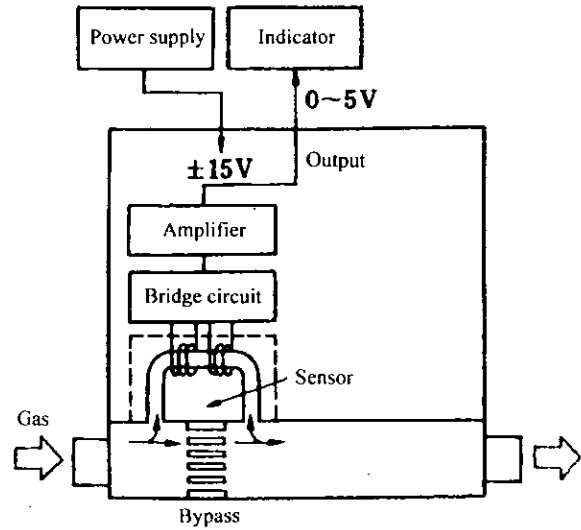

Figure 3.5 Mass flowmeter

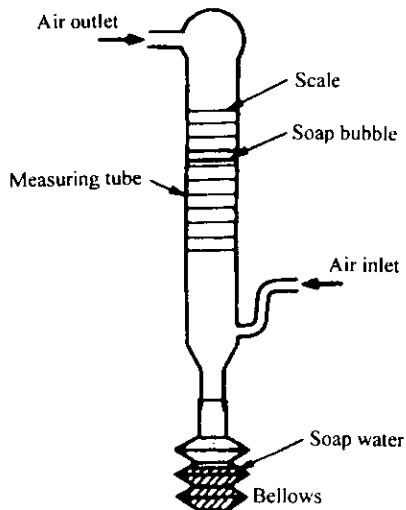

Figure 3.6 Soap film flowmeter

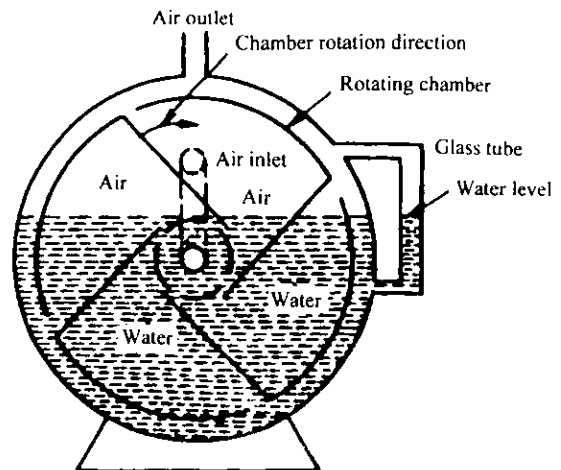

Figure 3.7 Wet gas meter

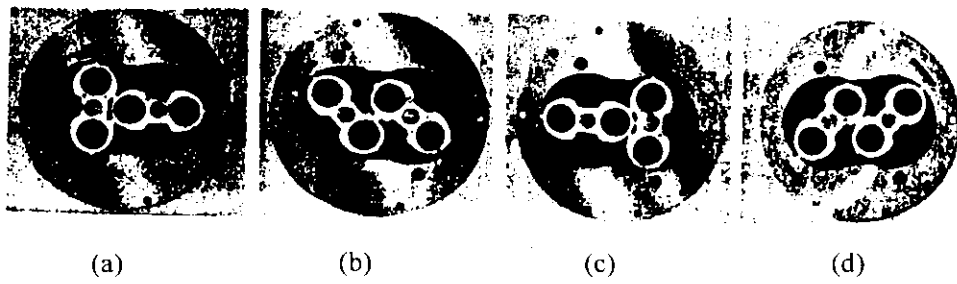

Figure 3.8 Roots meter

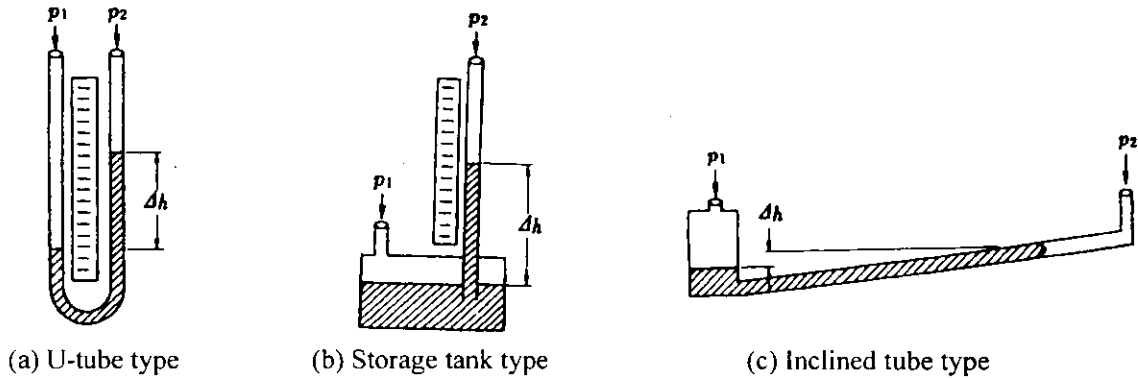

Figure 3.9 Manometer

3.4 Flow Rate Adjustment in Ambient Air Samplings

3.4.1 Flow controller

A flow controller is used to stabilize and adjust the flow rate of the sample gas when measuring ambient air. There are two methods of adjustment – namely manual and automatic.

(1) Manual adjustment method

This is widely used to adjust the air sample flow rate, and comprises of a needle valve as the flow rate control valve, a filter for air inlet at the suction volume adjustment bypass side, and a capillary to prevent pulsation (orifice), etc.

Figure 3.10 shows an example of a manual air sampling flow rate adjustment system.

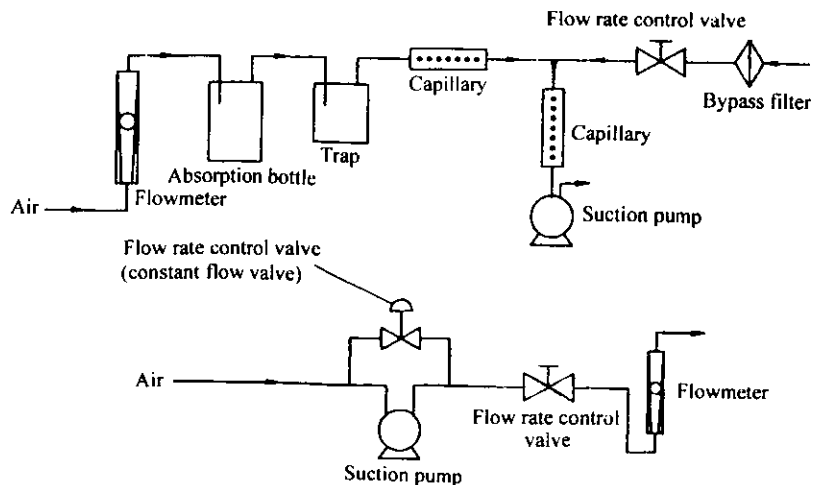
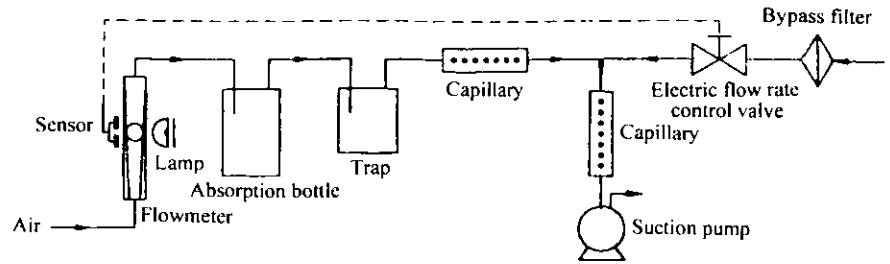

Figure 3.10 Example of an air sampling flow rate adjustment system (manual type)

(2) Automatic adjustment method

An automatic flow controller is used to stabilize the air sampling flow rate. There are three types, one of which controls the float position of the area flowmeter, another uses the mass flow controller, and the last is the pressure adjustment method. Figure 3.11 shows examples of an automatic air sampling flow rate adjustment systems



System by controlling the float position for area flowmeter

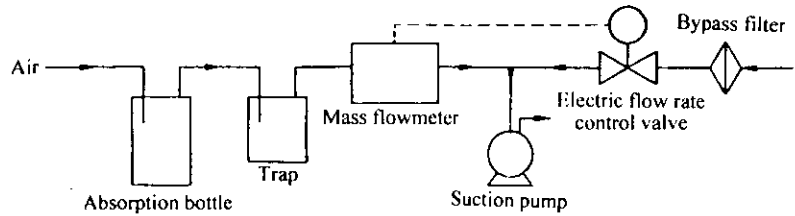

System of mass flow controller

Figure 3.11 Examples of air sampling flow rate adjustment systems (automatic type)

3.4.2 Scale calibration of the flowmeter

The flowmeter must be regularly cleaned and recalibrated as the inside of the tube becomes dirty with use, which causes variance in the measurements. Recalibration should be carried out by comparison with the indicated value on the calibrated flowmeter (standard flowmeter).

(1) Preparation of the standard flowmeter

In general, the standard flowmeter should be calibrated in accordance with the method specified by the 'JIS Z 8761 Flow rate measurement method using a float area flowmeter', but it is calibrated using a wet gas meter or precision membrane flowmeter (soap-and-water membrane flowmeter) in the configuration shown in Figure 3.12 for simplified method.

(2) Standard flowmeter and confirmation of the flow rate for high volume air samplers

Flowmeter for a high volume air sampler is calibrated as per the configurations shown in Figures 3.13 and 3.14.

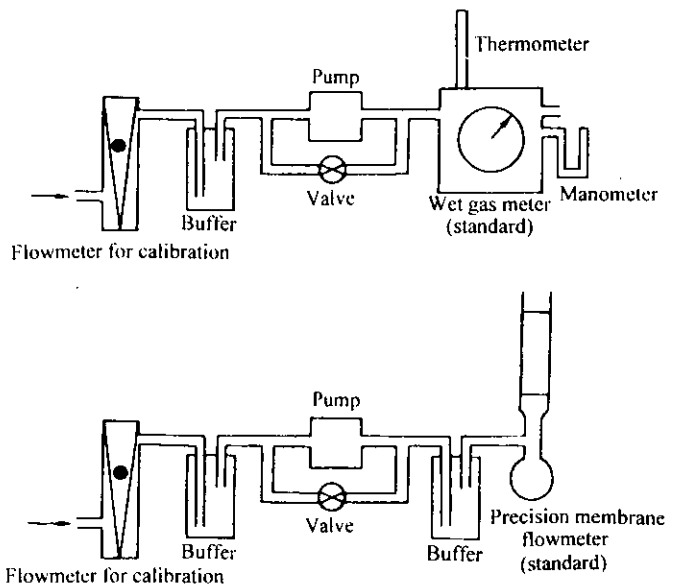

Figure 3.12 Example of scale calibration for standard flowmeter

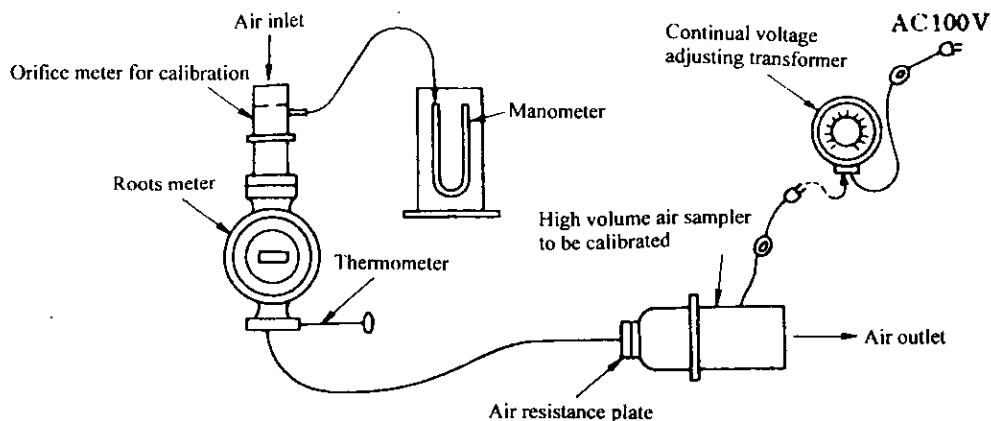

Figure 3.13 Making calibration curve for a calibration orifice based on roots meter

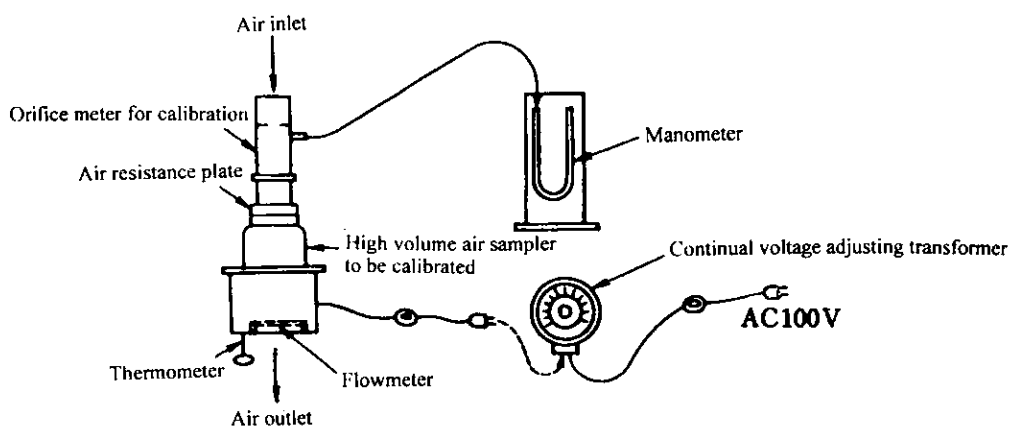

Figure 3.14 Flowmeter calibration of a sampler based on a calibration orifice meter

3.5 Current Status and Subjects Concerning Flow Rate Measurement of Ambient Air

Air pollutant is collected into absorption solvent when sampling ambient air, so changes in flow rate give significant effects to measurement accuracy. Float type area flowmeter (rotor meter) is widely used for normal ambient air sampling. Rotor meters are affected by the temperature and pressure of the air sample, so mass flowmeters are sometimes used instead. However, mass flowmeters are also affected by moisture in the sampled air, so this cannot be considered to be absolutely accurate either. Therefore, attach a dehumidifier to the flow rate measurement line to improve the accuracy of the measuring sampling flow rate as much as possible and to try to reduce humidity-induced changes in the flow rate.

3.6 Sampling Gaseous Matter

When sampling air, the sampling vessels are selected in accordance with the objectives, which are carried out in various ways.

Air pollutants are not always found in the constant concentration. In particular, if the generation source is close to the sampling site, the concentration may vary with time, so it is preferable to conduct air sampling over a longer period to obtain the average concentration at that site.

3.6.1 Natural ventilation method

Open the mouth of the sampling vessel, fix it at the measurement point and wait for air to enter the vessel in accordance with the natural ventilation, then close the mouth to retain the sample. An advantage of this technique is that the average concentration within the time range at the measurement point can be obtained, but it is not such an accurate method.

3.6.2 Vacuum vessel method

Vacuum the sample vessel before collection, and sampling can be done by simply opening the valve at the collection point. This method is suitable for situations where 'instant' sampling is required.

3.6.3 Sampling method on the dynamic flow

Suck out the air from one sampling hole on the vessel using an air pump at the measurement site to introduce the sample gas through another sampling hole. This is the optimal method for air sampling if one considers time and sample gas representivity.

3.6.4 Displacement method

Place a bag within a vessel and introduce and expel the air sample to/from the bag by removing and refilling the gas in the vessel outside the bag. Advantages of this method include that the air sample within the bag can easily be emitted and reintroduced, but the bag material must be selected with due consideration for the component to be measured.

3.6.5 Concentrating methods

(1) Adsorption method

This adsorbs and collects matter including the targeted components by ventilating the sample gas through a tube filled with adsorbent. Activated carbon, silica gel, molecular sieve, alumina, and backing for gas chromatographs are used as the adsorbents. Of these, activated carbon is the most widely used.

(2) Low temperature concentrating method

Insert the sampling tube into a vessel cooled by a coolant to make use of the principle that components of higher concentration than the vapor pressure of the coolant's components are collected. However, the efficiency for collecting the targeted components relies on the difference between the sample concentration and the vapor pressure value at the temperature of said component, the absorption rate, degree of dissolution to the collection material, shape of the trap, and gas flow rate, etc.

(3) Absorbent reaction method

The DNPH method, which is used to measure aldehyde within the air, is one such method.

3.6.6 Reaction solution absorption method

Put a suitable reaction absorption solvent for the targeted component into an impinger and sample the gaseous matter in the air at a constant suction flow rate.

3.7 Sampling Particulate Matter

3.7.1 Selection of sampling filter paper

Generally, there are five types of basic collection principles employed for filter papers, namely 'Inertial collision effect', 'Screening effect', 'Diffusion effect', 'Gravity (Precipitation) effect', and 'Electrostatic effect'. It is known that diffusion is effective when the diameter of minute particles is approximately $0.1\mu\text{m}$ or less, while both diffusion and screening are suitable if they are between $0.1\mu\text{m}$ and $0.5\mu\text{m}$, and inertial collision and screening are effective for particles of $0.5\mu\text{m}$ or more.

As for collection of the particulate matter, diffusion is effective for minute particles, while inertial collision, screening and gravity are effective for larger particles of about $2\mu\text{m}$ or more. Selection of the filter paper depends on the characteristics of the matter to be measured and the method of analysis. There are two types of filter paper for collecting particulate matter, namely fabric and porous membrane filters. The classification and type of each filter paper are shown in Table 3.2.

Table 3.2 Classification and characteristics of each filter paper

Classification	Types	Product Example	Moisture Absorption Amount (mg)*
Fibrous Filters	Cellulose fiber	No.5A	1.4 ± 0.8
	Glass fiber	AP20	0.36 ± 0.04
		T60A20	0.03 ± 0.01
	Quartz fiber	2000QAST	0.17 ± 0.03
Porous Membrane Filters	Cellulose ester membrane	AA pore size $0.3\mu\text{m}$	0.52 ± 0.11
	Fluoro pore membrane	AP07 pore size $10\mu\text{m}$	0.07 ± 0.02
	Nuclear pore membrane	Pore size $0.5\mu\text{m}$	0.09 ± 0.04
	Silver membrane	FM1.2 pore size $1.2\mu\text{m}$	0.012 ± 0.005

* Changes in weight after being left in an environment with 90% relative humidity for 24 hours

3.7.2 Weighing of filter paper

Weigh the collection filter paper before and after use with a direct reading balance with a sensitivity of 0.1mg or greater after leaving it in a balance room with fixed temperature and humidity for 24 hours. Great care must be taken when weighing and handling the filter paper as it is easily damaged. Weigh each sample at least twice and confirm that such readings are nearly identical. If they differ substantially, repeat the weighing procedure until stable values are obtained.

3.7.3 Storing collection filter papers

It is best to analyze the filter paper immediately after sampling, but handling a number of samples is more effective in reality, so they should be stored in accordance with the type of filter paper material and analysis objective.

The storage method for filter paper that has been used for collection differs depending on the analysis objectives. Heavy metal components can be stored at room temperature after being placed in a plastic bag or suchlike to avoid contamination from within the room. Anionic or organic components are very volatile and easily deteriorate at room temperature, so they need to be kept refrigerated or frozen. Also, there are some substances whose concentration certainly decreases under light at room temperature such as benzo[a]pyrene. Thus, it is better to store samples that are used to analyze a number of components in a dark and frozen state.

3.7.4 Balance

(1) Points to note when setting up the balance

- 1) It is preferable to place the balance in an exclusive room such as a balance room. If there is no balance room, it should be placed somewhere that is used by few people and where the room temperature is stable.
- 2) The balance should not be placed anywhere that is at all unstable or shakable.
- 3) It should not be placed near a heat source such as a heater or in direct sunlight, but rather should be as far from any heat as possible.
- 4) If there is a balance room, the room humidity should ideally be $60\% \pm 10\%$ and 20°C or more.

(2) Points to note on usage

- 1) When using a balance, maintain an upright posture and do not place your elbows on the balance table. Do not get too close to the balance either because the more minute the balance reading is, the more easily its zero point is affected by human body temperature.
- 2) Turn the operation handle very gently to make operating status of the balance.
- 3) When weighing a hygroscopic sample, it is best to weigh it after operation of the balance is settled.
- 4) When weighing a sample with electrostatic chargeability, such as a membrane filter, use aluminum foil or suchlike to prevent electrostatic charging before weighing.

4. Sampling of Flue Gas

This video introduces the sampling of sulfur oxides, nitrogen oxides, and sampling status for soot and dust as a representative film in the field to ensure understanding of flue gas sampling at their source.

There are various flue gas sampling methods which are specified per target item. This text only provides introductory information as it is impossible to give full details here. Refer to the JIS guidebook or suchlike for specific procedures on each item.

4.1 Flue Gas Sampling Position and Hole

In general, the best position for taking a representative gas sample is somewhere with a comparatively uniform flow, such as in a straight section of the duct or chimney as far as possible from any bends or areas where the cross section undergoes rapid change.

If there is a crack in the flue duct that allows much air to enter, the flue gas will lack uniformity, so this is not preferable.

Set-up a sampling hole for a collecting tube to be inserted rectangularly to the flow of the flue gas in a place where measurements can be carried out safely and easily. It is preferable to set up two sampling holes at a cross section of the flow duct which intersect each other rectangularly (at 90°). It is preferable to arrange the sampling hole with a diameter of 15cm or more so that a dust-sampling nozzle can be inserted. For this, a steel pipe (10~15cm long) with a flange is welded, and it should normally be closed with a lid.

Also, scaffolding and handrails should be arranged at the appropriate height as well as preparing steps when required. It is preferable that it is located close to a power source in order to operate any necessary equipment, such as a suction pump. (See note 1)

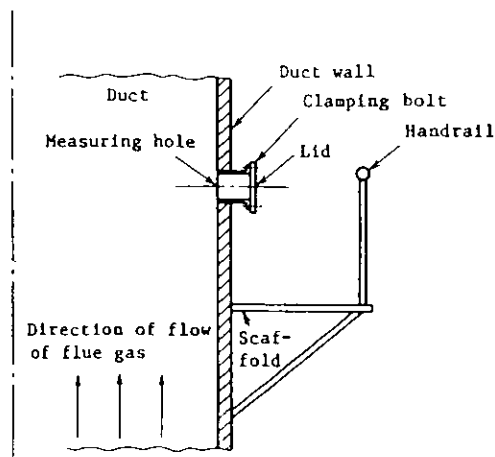

Figure 4.1 Example of sampling hole structure

Note 1: If the sampling position is high up, a suction pump or suchlike may be placed at ground level, and operations carried out at ground and higher levels by connecting long rubber suction tubes.

4.2 Sampling of Sulfur Oxides

There are four chemical analysis methods (such as turbidimetry) for analyzing sulfur oxides (SO_x : $\text{SO}_2 + \text{SO}_3$) in flue gases (See Note 2). A sampling case study using ion chromatography is introduced in the video.

Also, continuous analysis is sometimes carried out using an automatic analyzer. In that case, the targeted component is SO_2 instead of SO_x .

4.2.1 Sampling apparatus for sample gas

The sampling apparatus used for gas sampling is common for most components when using chemical analysis methods. General points are specified in the JIS regulations as well. (See Note 3.)

Structural example of an SO_x sampling apparatus is shown in Figure 4.2.

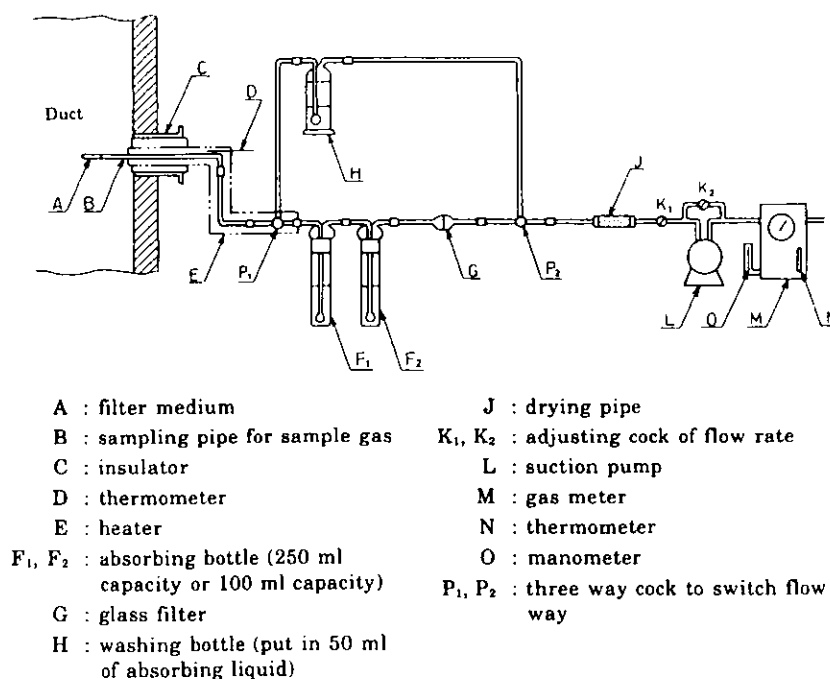

Figure 4.2 Example of sampling apparatus for SO_x

(1) Collecting tube

This is inserted into the sampling hole that is set into the chimney or flue duct to extract the sample gas. A hard glass pipe is normally used as it is not eroded by corrosive gases within the flue gases. (Stainless steel is used when sampling for hydrogen fluoride.)

Note 2: JIS K 0103-1995 'Methods for determination of sulfur oxides in flue gases'

Note 3: JIS K 0095-1994 'Methods for Sampling of Flue gas'

Filter medium is attached to the tip of the sampling pipe to prevent dust within the flue gases mixing with the sample. Cylindrical filters made of silica wool or quartz fiber are used as the filter medium in most cases.

(2) Gas absorbing bottle

This is a glass bottle designed to absorb sulfur oxides (SO_x). Connect two bottles of capacities of 100ml or 250ml in a straight line, and pour approximately 50ml of absorbent into each.

Hydrogen peroxide solution (1+9) is used as the absorbent when using turbidimetry, while hydrogen peroxide solution (1+99) is used for ion chromatography. Hydrogen peroxide is degraded by direct sunlight and high temperatures, so care must be taken with its storage.

(3) Heating probe and connecting tube

If moisture within the sample gas condenses, any SO_x within the flue gas is liable to dissolve into it and create negative tolerance, so the probe and connecting tube must be heated by wrapping a ribbon heater around them.

Also, use the shortest possible connecting tubes.

(4) Suction pump

A compact type is preferable provided it has sufficient capability. External air must not leak at the pump area because a flow meter and gas meter will be attached after the pump.

(5) Flow meter, gas meter

The suction gas volume must be measured to determine the concentration of any SO_x within the flue gases. A compact wet gas meter (or dry gas meter) that can read integrated values and indicates one liter per 360° rotation of the indicator is normally used. The gas meter is calibrated under conditions in which air is released (1 atm) at the exit side, so it is attached after the suction pump.

(6) Drying bottle

Attach a drying bottle containing silica gel in front of suction pump to absorb moisture discharged from the absorbing bottle.

4.2.2 Sampling procedure

- 1) Pour in absorbent after assembling the sampling system, and test that there are no leaks.
- 2) After making sure there are no leaks, insert and secure the sampling tube to the sampling hole, and fill the gap using waste cloth or suchlike
- 3) Suck through a sufficient volume of flue gas to replace any remaining air in the sampling tube.
- 4) Record the integrated value of the gas meter, activate the pump and sample approximately 1 liter per minute for 20~30 minutes. Also record the temperature at the gas meter during sampling.
- 5) Read the integrated value of the gas meter again upon completion.
- 6) Suction volume is calculated from the difference, but it is converted to a volume under standard conditions (temperature: 0°C; pressure: 1 atm). When a wet gas meter is used, it should be converted to a dry gas volume by compensating for the volume according to the steam pressure.

4.3 Sampling of Nitrogen Oxides

There are two methods – one using an automatic analyzer, the other being chemical analysis aimed at nitrogen oxides (NO + NO₂). (See Note 4)

The number of cases of continuous analysis that use automatic analyzer has recently increased. The concentrations of NO, NO₂ and NO_x are shown on automatic analyzers.

This video introduces a sampling case using the zinc reduction naphthyl lenediamine absorptiometry method (Zn-NEDA method).

4.3.1 Gas sampling using the Zn-NEDA method

A vacuumed round-bottomed flask or syringe is used to collect gas as opposed to other parameters when adopting this method. NO_x within the sample gas is converted to nitrate ions through absorption by the absorbent (about 20ml dilute sulfuric acid mixed with pure water) in the presence of ozone.

Sample gas in the same position at least twice within a short period, and analyze each sample.

4.3.2 Gas sampling apparatus for NO_x

The structure of the sampling apparatus for NO_x is shown in Figure 4.3.

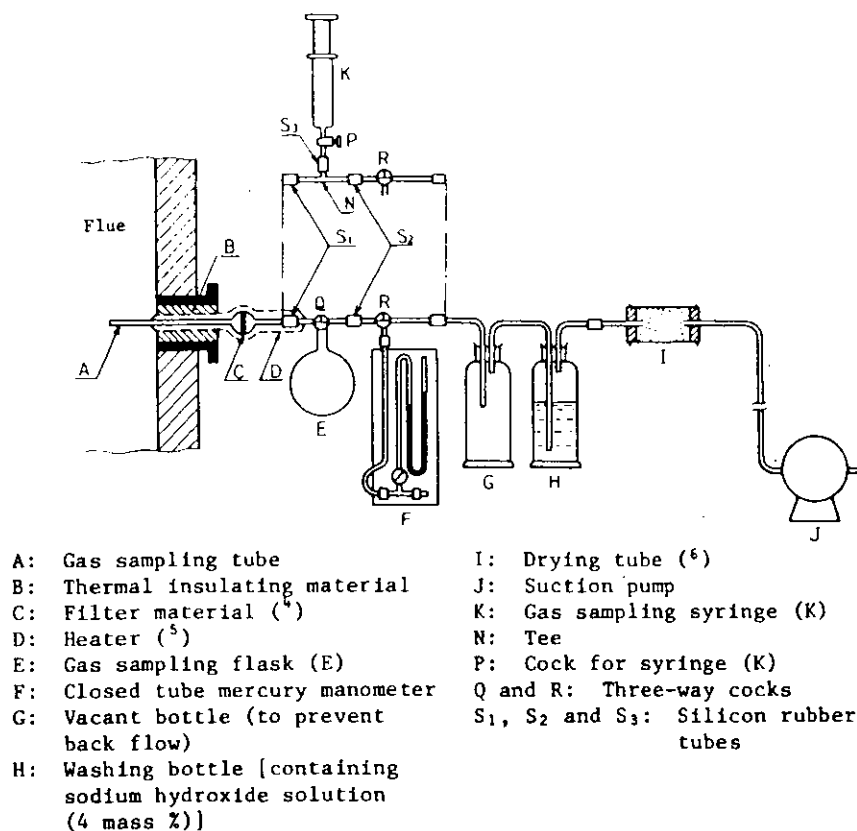

Figure 4.3 NO_x sampling apparatus (example)

Note 4: JIS K 0104-1984 'Methods for determination of nitrogen oxides in flue gases'

Use a one-liter round-bottomed flask with a three-way cock, and conform to the SO_x example for probe, sampling tubes and filter medium.

4.3.3 Sampling procedure

- 1) Pour in about 20ml of absorbent and use a vacuum pump to reduce the pressure until the absorbent begins to vaporize. Measure the pressure and temperature in the flask at this stage.
- 2) Switch the three-way cock and suck out the sample gas. Then shake it for one minute.
- 3) Leave it to cool down to room temperature.
- 4) After measuring the pressure and temperature, add oxygen including ozone to allow the sample to be oxidized to a nitrate ion. Shake it for one minute, leave it for a while and this will then be the sample for analysis.
- 5) Calculate the sampled gas volume required to obtain the concentration as the dry gas volume under standard conditions (0°C; 1 atm).

4.3.4 Conversion using oxygen concentration

The concentration of NO_x within the flue gas in the duct is often the value after dilution with outside air. The values that have been converted using the fixed standard oxygen density should be displayed compensating for the effects of dilution to correspond with the regulations concerning emission. Thus, oxygen concentration must generally be measured in NO_x sampling.

Orsat analyzers have been used to measure oxygen concentration (see Note 5), but recently the number of cases carrying out continuous analysis using automatic analyzers (magnetic type or zirconia type) has increased (see Note 6).

4.4 Dust Sampling

4.4.1 Measurement objectives and targets

There are several methods for measuring dust concentration at sources. One involves the evaluation of color tone of the emitted smoke, another evaluates on the basis of light penetration and scattering, and the last separates dust from flue gases and measures its mass and property.

The most basic measurement method is to use filter paper to collect dust and then measure its mass. (See Note 7.)

The targeted dust is solid particles that can be separated by filtering, and whose water content has been evaporated off.

Note 5: JIS K 0301-1998 'Methods for determination of oxygen in flue gas'

Note 6: JIS B 7983-1994 'Continuous analyzers for oxygen in flue gas'

4.4.2 Outline of dust sampling

A summary of the dust measurement procedure is shown in Figure 4.4. Refer to the JIS guidelines for detailed operational procedures and norms.

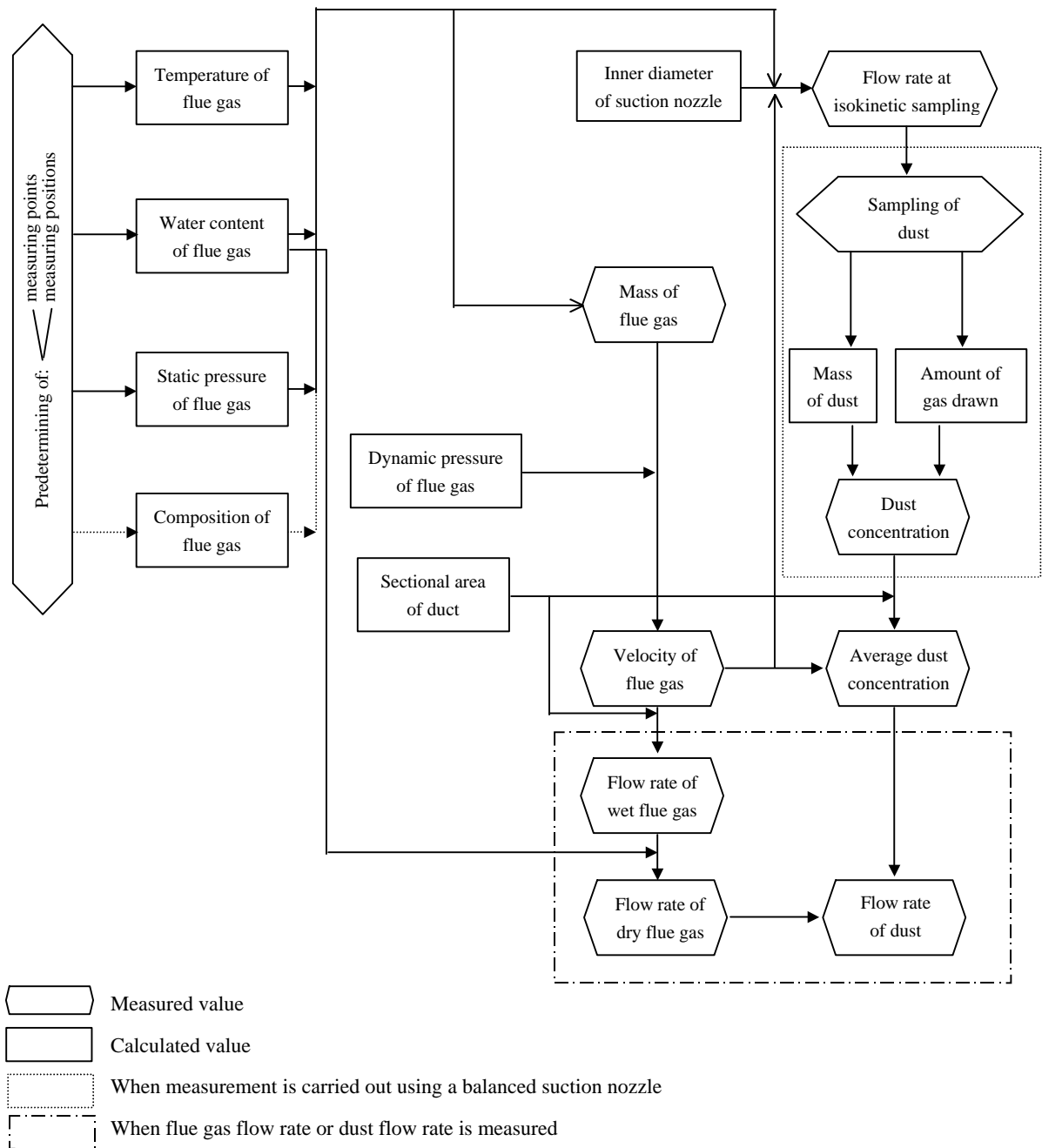

Figure 4.4 Outline of measuring method

Note 7: JIS Z 8808-1995 'Method of Measuring Dust Concentration in Flue Gases'

4.4.3 Measurement points

The same concept as is used for gas can be adopted as the measurement position for dust concentration. However, with regard to dust, measurements at a prescribed number of points or more in a cross section are specified in accordance with the size of the flue duct.

As regards cylindrical ducts which have round cross sections as shown in Figure 4.5, the area is separated from the center towards in a radial direction, and measurements are carried out at each prescribed distance. In the square duct, measurements are taken at the center of each separate and equal square that has been created in the cross sections. Thus, the cross-sectional shape and size of the duct to be measured must be known beforehand.

When it is a small-scale duct, measurements can be carried out at a central point. Also, if the data from the measurement results show that the flow velocity of the flue gases is distributed symmetrically on either side, the number of measurement points can be reduced to those points in one half or quart from the center point. Furthermore, when dust concentration distribution is already known as a result of previous measurements, measurements can be taken from a representative point where an average concentration value can be obtained.

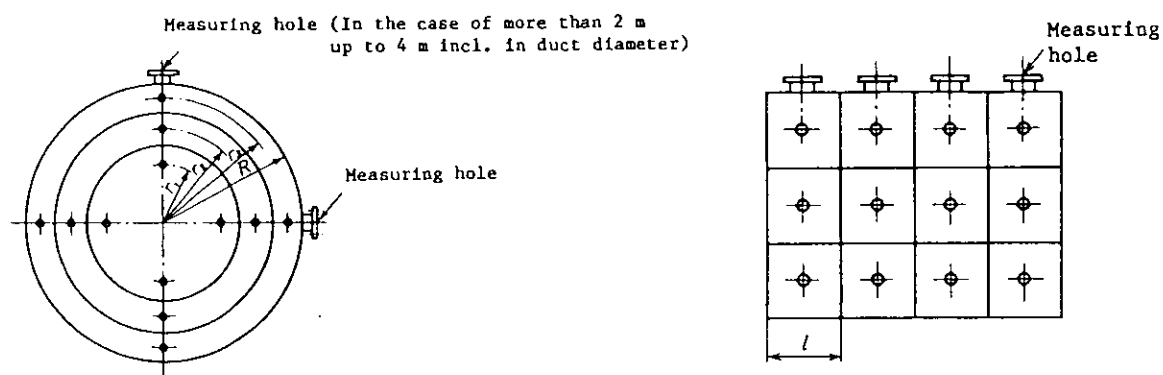

Figure 4.5 Examples of measurement points for ducts with round and square sections

4.4.4 Structure of the sampling apparatus

Dust sampling apparatus can be classified into several types according to the methods. Figure 4.6 shows a structural example of the most basic manual sampling apparatus. In Japan, the 'Type 1' method in which the collector is inserted into the duct is most commonly used.

(1) Sample collection part

The sample collection part, which is made up of a suction nozzle and collector (filter paper holder), etc., is inserted into the flue gas flow when Type 1 method is adopted.

The nozzle sucks sample gases in accordance with the flue gas flow velocity, so several types with different internal diameter sizes should be prepared. (Different sizes coming in 2mm gradations are available.)

Circular filter paper or cylindrical filter paper is used to collect dust in accordance with the concentration at its source. Figure 4.7 shows the shape of each collector. Filter paper made of quartz fibers that are highly heat-resistant and do not change in weight due to absorption of acidic gases are generally used.

Dust tubes filled with silica wool are also used at sources where the dust concentration is extremely high.

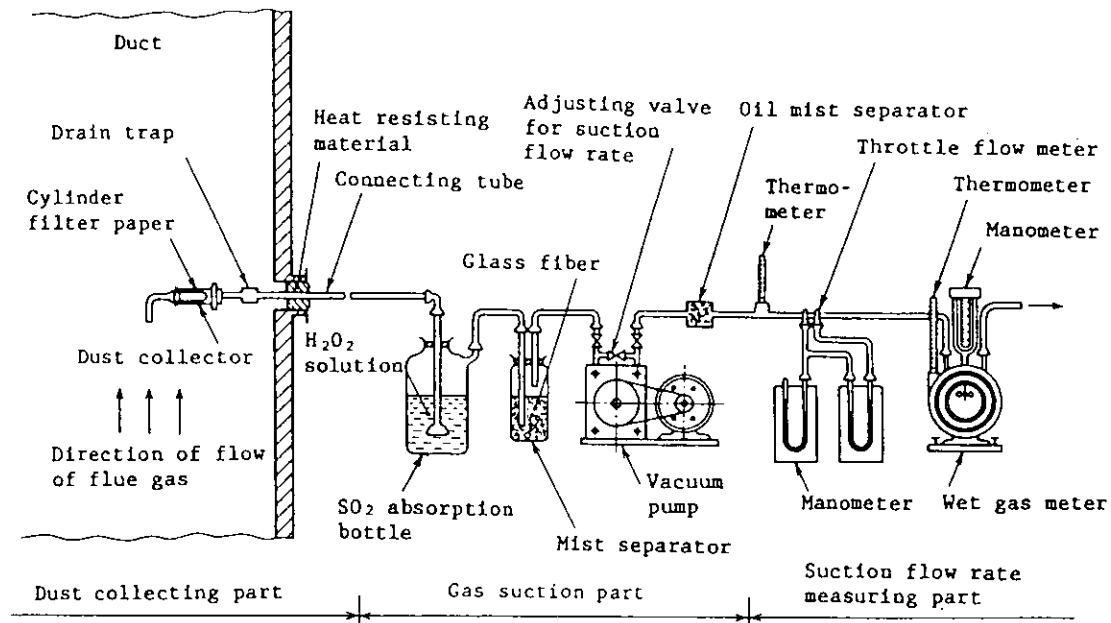

Figure 4.6 Example of construction of ordinary-type sampling apparatus (JIS type 1)

(2) Gas suction part

A vacuum pump or diaphragm pump is used to extract gas at the required flow rate. If acidic gases and moisture within the flue gases enter the pump, the innards of the pump may rot and cause failure, so an SO₂ absorption bottle containing hydrogen peroxide (approximately 3%) and a mist separation bottle filled with glass wool must be attached in front of the pump.

(3) Suction flow rate measuring part

Connect an integrated value type gas meter (generally wet gas meters are used) after the pump, and measure the sucked sample gas volume. Area flow meters (float type) are convenient for checking the flow rate if attached.

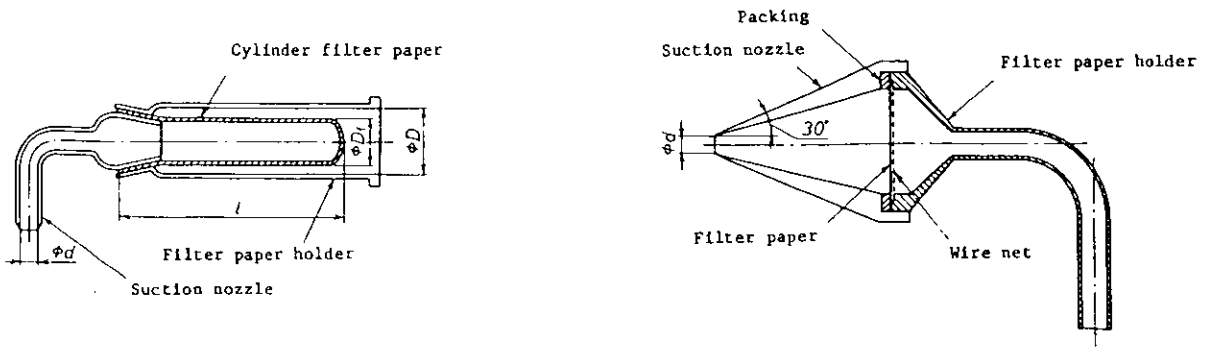

Figure 4.7 Examples of dust collectors using circular and cylindrical filter papers

4.4.5 Isokinetic sampling

When collecting dust, the sample gas must be drawn from the nozzle at the same speed as the flue gas flow velocity. (This is known as 'isokinetic sampling'.)

Figure 4.8 shows the effect of dust concentration on measured values through the relationship between the flue gas flow velocity and the suction speed of the nozzle.

If the suction speed (V_n) is less than the flue gas flow velocity (v), the flue gas overflows around the nozzle, but particles move straight into the nozzle under the force of their own inertia. Thus, the measurement value appears higher than the actual dust concentration. Conversely, when the suction speed (V_n) is greater than the flue gas flow velocity (v), gas around the nozzle enters and dilutes the concentration, so the measured value is lower than the real concentration.

The tolerance due to isokinetic sampling is greater when the particle diameter is larger; for example, particles that are sampled at the entry of the dust collecting system and dust resulting from the combustion of coal. However, there is little effect from sub-micron sized particles.

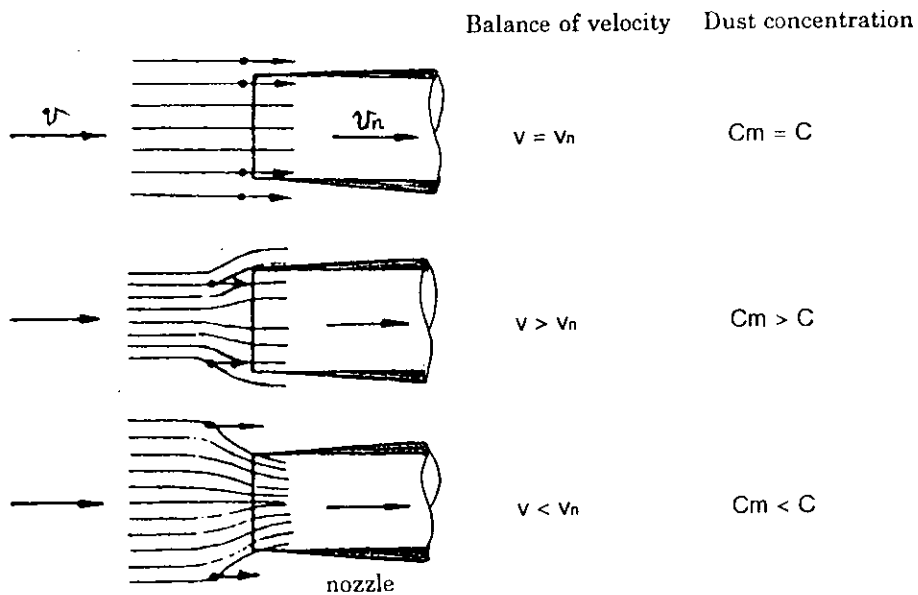

Figure 4.8 Concept of isokinetic sampling

4.4.6 Measurement of flue gas flow rate

Flue gas flow rate at each measurement point must be checked before sampling in order to carry out isokinetic sampling of dust and to obtain data on the emitted pollutant volume per hour.

The special pitot pipe (western type) shown in Figure 4.9 is generally used to measure flow rate, and measure static and dynamic pressure within the flues duct. The Pitot tube coefficient that has already been calibrated by the manufacturers should be used to convert the dynamic pressure into flow velocity.

Use the inclined manometer shown in Figure 4.10 to increase the differential pressure as the dynamic pressure is small.

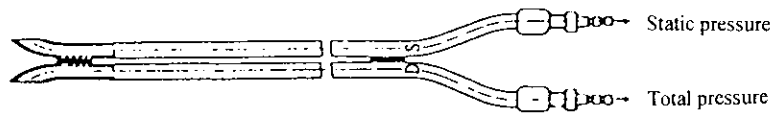

Figure 4.9 Special western Pitot tube

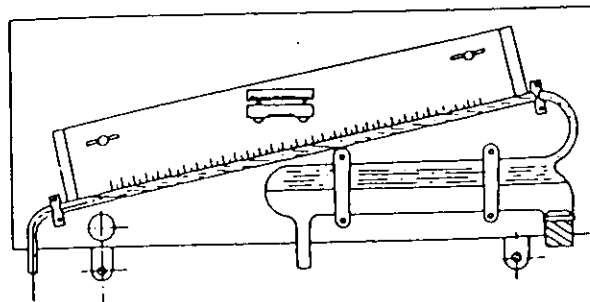

Figure 4.10 Inclined tube manometer

4.4.7 Measurement of water content

Use the balance to measure weight changes after the water content is absorbed by the moisture absorption tube to obtain the water content within the flue gas.

Fill the moisture absorption tube with granulated calcium chloride as shown in Figure 4.11, plug it with glass wool to prevent the scattering of absorbent, and then weigh it.

The sample gas is drawn from a point near the center of the duct cross section, and connected to two moisture absorption tubes in a straight line and cooled in a water bath. The suction flow rate shall be under 0.1 liters per minute per gram of absorbent in each moisture absorption bottle, and suction should be continued until 0.1~1g of moisture is trapped.

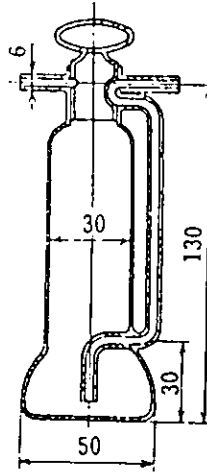

Figure 4.11 Sheffield-type moisture absorption tube

4.4.8 Other measurements

As mentioned above, the flue gas temperature and oxygen density must be measured as well as moisture content, in addition to the flue gas velocity (and static pressure) when measuring dust concentration.

Flue gas temperatures are generally measured with a thermocouple.

Also, the oxygen density is measured using an Orsat analyzer or automatic analyzer as mentioned in the section on NO_x .

Text Book for Sampling for Environmental Monitoring
- Analysis Video Series for Environmental Technology Transfer -

March 2000 (Not for sale)

Compiled and Published by:

Overseas Environmental Cooperation Center, Japan
Shibakoen Annex 7th floor, 3-1-8 Shibakoen, Minatoku,
Tokyo 105-0011, JAPAN

Phone: 81-3-5472-0144

Fax: 81-3-5472-0145

Funded by:

Office of Overseas Environmental Cooperation,
Global Environment Department,
Environment Agency of Japan
No.5 Godochosha, 1-2-2, Kasumigaseki, Chiyodaku,
Tokyo 100-8975, JAPAN

Phone: 81-3-3581-3351

Fax: 81-3-3581-3423



Eco mark

Printed on recycled paper.